



ELECTRAPIX PAR 7

User Manual

©2024 ADJ Products, LLC all rights reserved. Information, specifications, diagrams, images, and instructions herein are subject to change without notice. ADJ Products, LLC logo and identifying product names and numbers herein are trademarks of ADJ Products, LLC. Copyright protection claimed includes all forms and matters of copyrightable materials and information now allowed by statutory or judicial law or hereinafter granted. Product names used in this document may be trademarks or registered trademarks of their respective companies and are hereby acknowledged. All non-ADJ Products, LLC brands and product names are trademarks or registered trademarks of their respective companies.

ADJ Products, LLC and all affiliated companies hereby disclaim any and all liabilities for property, equipment, building, and electrical damages, injuries to any persons, and direct or indirect economic loss associated with the use or reliance of any information contained within this document, and/or as a result of the improper, unsafe, insufficient and negligent assembly, installation, rigging, and operation of this product.

Europe Energy Saving Notice

Energy Saving Matters (EuP 2009/125/EC)

Saving electric energy is a key to help protecting the environment. Please turn off all electrical products when they are not in use. To avoid power consumption in idle mode, disconnect all electrical equipment from power when not in use. Thank you!

DOCUMENT VERSION



Due to additional product features and/or enhancements, an updated version of this document may be available online.

Please check www.adj.com for the latest revision/update of this manual before beginning installation and/or programming.

Date	Document Version	Software Version	DMX Channels	Notes
03/20/2024	1.0	1.00	5 / 6 / 9 / 13 / 22 / 24 / 42 / 45 / 60 Ch	Initial release
04/09/2024	1.1	N/C	No Change	Added Battery Charging
05/17/2024	1.2	N/C	No Change	Updated System Menu, Battery Charging
09/10/2024	1.3	N/C	No Change	Added Snoot Installation Instructions

CONTENTS

Introduction	4
Limited Warranty (USA Only)	5
Warranty Registration Features	6
IP65 Rated	7
Safety Precautions	8
Battery Warnings	10
Battery Charging	11
Overview	12
Installation Guidelines	13
Accessory Installation	18
Remote Device Management (RDM)	21
Control Panel	22
System Menu	23
UC IR Remote	27
IR Default Values Editing IR Button Values	28
DMX Set Up	29
DMX Traits	31
Color Macros Chart	37
Pixel Flip	41
Dim Modes	42
Primary-Secondary Set Up Multi Unit Power Linking	43
Maintenance Guidelines	44
Torque Settings for Screws	45
IP Test Parameters	46
Dimensional Drawings	47
Specifications	48
Ordering Information FCC Statement	49

INTRODUCTION

Unpacking: Thank you for purchasing the ElectraPix Par 7 Pak by ADJ Products, LLC. Every device has been thoroughly tested and has been shipped in perfect operating condition. Carefully check the shipping carton for damage that may have occurred during shipping. If the carton appears to have been damaged, carefully inspect your fixture for any damage and be sure all accessories necessary to operate the unit have arrived intact. In the event that damage has been found or parts are missing, please contact our toll free customer support number for further instructions. Do not return this unit to your dealer without first contacting customer support.

Introduction: The ElectraPix Par 7 Pak is a comprehensive lighting solution that combines cutting-edge technology with convenience and portability. This package includes everything you need to elevate your lighting setup for events, performances, or any situation where vibrant and dynamic illumination is essential. The ADJ Lighting ElectraPix Par 7 is a IP65-rated, battery powered, wireless DMX LED fixture. It features seven 20-Watt Hex Color LED (RGBAL+UV), Aria X2 wireless DMX and has a battery life up to 10 hours. **This product is intended to be used by professionally trained personnel only and is not suitable for private use.**

Customer Support: Contact ADJ Service for any product related service and support needs. Also visit forums.adj.com with questions, comments or suggestions.

Parts: To purchase parts online visit:

<http://parts.adj.com> (US)

<http://www.adjparts.eu> (EU)

ADJ SERVICE USA - Monday - Friday 8:00am to 4:30pm PST

Voice: 800-322-6337 | Fax: 323-582-2941 | support@adj.com

ADJ SERVICE EUROPE - Monday - Friday 08:30 to 17:00 CET

Voice: +31 45 546 85 60 | Fax: +31 45 546 85 96 | support@adj.eu

ADJ PRODUCTS LLC USA

6122 S. Eastern Ave. Los Angeles, CA. 90040

323-582-2650 | Fax 323-532-2941 | www.adj.com | info@adj.com

ADJ SUPPLY Europe B.V

Junostraat 2 6468 EW Kerkrade, The Netherlands

+31 (0)45 546 85 00 | Fax +31 45 546 85 99

www.adj.eu | info@adj.eu

ADJ PRODUCTS GROUP Mexico

AV Santa Ana 30 Parque Industrial Lerma, Lerma, Mexico 52000

+52 (728) 282-7070

Warning! While the ElectraPix Par 7 fixtures are IP65-rated, the other components in this package are intended for indoor use only! Do not expose to rain or moisture!

CAUTION! There are no user serviceable parts inside this unit. Do not attempt any repairs yourself, as doing so will void your manufacturer's warranty. In the unlikely event your unit may require service, please contact ADJ Products, LLC.

Do not discard the shipping carton in the trash. Please recycle when ever possible.

LIMITED WARRANTY (USA ONLY)

- A. ADJ Products, LLC hereby warrants, to the original purchaser, ADJ Products, LLC products to be free of manufacturing defects in material and workmanship for a prescribed period from the date of purchase (see specific warranty period on reverse). This warranty shall be valid only if the product is purchased within the United States of America, including possessions and territories. It is the owner's responsibility to establish the date and place of purchase by acceptable evidence, at the time service is sought.
- B. For warranty service, you must obtain a Return Authorization number (RA#) before sending the product back—please contact ADJ Products, LLC Service Department at 800-322-6337. Send the product only to the ADJ Products, LLC factory. All shipping charges must be prepaid. If the requested repairs or service (including parts replacement) are within the terms of this warranty, ADJ Products, LLC will pay return shipping charges only to a designated point within the United States. If the entire instrument is sent, it must be shipped in its original package and packaging material. No accessories should be shipped with the product. If any accessories are shipped with the product, ADJ Products, LLC shall incur no liability whatsoever for loss of or damage to any such accessories, nor for the safe return thereof.
- C. This warranty is void if the product serial number and/or labels are altered or removed; if the product is modified in any manner which ADJ Products, LLC concludes, after inspection, affects the reliability of the product; if the product has been repaired or serviced by anyone other than the ADJ Products, LLC factory unless prior written authorization was issued to purchaser by ADJ Products, LLC; if the product is damaged because it was not properly maintained as set forth in the product instructions, guidelines and/or user manual.
- D. This is not a service contract, and this warranty does not include maintenance, cleaning, or periodic checkup. During the period specified above, ADJ Products, LLC will replace defective parts at its expense with new or refurbished parts, and will absorb all expenses for warranty service and repair labor by reason of defects in material or workmanship. The sole responsibility of ADJ Products, LLC under this warranty shall be limited to the repair of the product, or replacement thereof, including parts, at the sole discretion of ADJ Products, LLC. All products covered by this warranty were manufactured after August 15, 2012, and bear identifying marks to that effect.
- E. ADJ Products, LLC reserves the right to make changes in design and/or improvements upon its products without any obligation to include these changes in any products theretofore manufactured.
- F. No warranty, whether expressed or implied, is given or made with respect to any accessory supplied with products described above. Except to the extent prohibited by applicable law, all implied warranties made by ADJ Products, LLC in connection with this product, including warranties of merchantability or fitness, are limited in duration to the warranty period set forth above. And all warranties, whether expressed or implied, including warranties of merchantability or fitness, are limited in duration to the warranty period set forth above. The consumer's and/or dealer's sole remedy shall be such repair or replacement as is expressly provided above; and under no circumstances shall ADJ Product, LLC be liable for any loss and/or damage, direct and/or consequential arising out of the use of, and/or inability to use this product.
- G. This warranty is the only written warranty applicable to ADJ Products, LLC products, and supersedes all prior warranties and written descriptions of warranty terms and conditions heretofore published.

MANUFACTURER'S LIMITED WARRANTY PERIODS:

- Non-LED Lighting Products = 1-Year (365 Days) (Including Special Effect Lighting, Intelligent Lighting, UV lighting, Strobes, Fog Machines, Bubble Machines, Mirror Balls, Par Cans, Trussing, Lighting Stands, Power/Data Distribution, etc. excluding LED and lamps)
- Laser Products = 1-Year (365 Days) (excluding laser diodes which have a 6-Month Limited Warranty)
- LED Products = 2-Year (730 Days) (excluding batteries which have a 180 Day Limited Warranty)
- NOTE: 2-Year (730 Days) Limited Warranty ONLY applies to product purchased within the United States. StarTec Series = 1-Year (365 Days) (excluding batteries which have a 180 Day Limited Warranty)
- ADJ DMX Controllers = 2 Year (730 Days)
- American Audio Products = 1 Year (365 Days)

WARRANTY REGISTRATION

Please fill out the enclosed warranty card to validate your purchase. All returned service items, whether under warranty or not, must be freight pre-paid and accompanied by a return authorization (R.A.) number. The R.A. number must be clearly written on the outside of the return package. A brief description of the problem as well as the R.A. number must also be written down on a piece of paper included in the shipping carton. If the unit is under warranty, you must provide a copy of your proof of purchase invoice. You may obtain an R.A. number by contacting our customer support team. All packages returned to the service department not displaying an R.A. number on the outside of the package will be returned to the shipper.

FEATURES

- 7 Pixel, Hex Color LED (RGBAL+UV) LED Par
- Battery or Wall Powered
- Battery operation can be selected by the user for durations ranging from 5 to 20 hours
- Individual Pixel Control
- Built-In Foreground LED Programs
- Built-In Background LED Programs
- Variable White Color Temperature Control (2,300K ~ 9,900K)
- English & Spanish User Menu
- Built-In Alarm
- Color Calibrated LEDs
- User Selectable LED Refresh Rates (900Hz ~ 25K)
- 6 User Selectable Dim Modes
- 4 User Selectable Dim Curves
- Electronic Strobe (0.3Hz ~ 11Hz)
- Electronic Dimming
- Three DMX Channel Modes
- RDM

INCLUDED ITEMS

- UC-IR24 Remote Control (x1)
- Outdoor Locking Power Cable (x1)
- Gel Frame Holder (x1)
- 20° Diffusion Filter (x1)

IP65 RATED

The **International Protection (IP)** rating system is commonly expressed as “**IP**” (Ingress Protection) followed by two numbers (i.e. IP65), where the numbers define the degree of protection. The first digit (Foreign Bodies Protection) indicates the extent of protection against particles entering the fixture, and the second digit (Water Protection) indicates the extent of protection against water entering the fixture. An **IP65** rated lighting fixture is designed and tested to protect against the ingress of dust (6), and low-pressure water jets from any direction (5).

NOTE: THIS FIXTURE IS INTENDED FOR TEMPORARY OUTDOOR USE ONLY!

Maritime/Coastal Environment Installations: A coastal environment is seaside adjacent, and caustic to electronics through exposure to atomized salt-water and humidity, whereas maritime is anywhere within 5-miles of a coastal environment.



NOT suitable for maritime/coastal environment installations. Installing this fixture in a maritime/coastal environment may cause corrosion and/or excessive wear to the interior and/or exterior components of the fixture. Damages and/or performance issues resulting from installation in a maritime/coastal environment will void the manufactures warranty, and will NOT be subject to any warranty claims and/or repairs.

Maritime installations require additional preparation, and additional service intervals may be needed given the maritime use. In general, IP ratings presuppose freshwater conditions VS maritime conditions, which are typically more “caustic” to IP fixtures (both internally and externally). A duty-cycle may also be needed when units are not in use. During times of high humidity and colder temperatures, condensation may occur internally so the fixture may require a duty-cycle to bring it up to running temperature, allowing any accumulation of moisture to be expelled via the vent valve. Recommendations can change based on installation environmental circumstances. A waterproof dome or similar device is recommended for use in permanent outdoor installations. When using a dome, refer to manufacturer recommendations for duty-cycle.

NOTE: NOT ALL FEATURES LISTED ARE AVAILABLE ON ALL FIXTURES; THE FOLLOWING INSTRUCTIONS MAY NOT APPLY. CONTACT SUPPORT FOR ADDITIONAL DETAILS.

Exterior Maintenance: Inspect the exterior every 30-days. The unit must be powered off/disconnected. Inspect optics to determine if the lens is obstructed, then clean optics and chassis accordingly. Based on initial finding, schedule maintenance accordingly, keeping in mind that exterior maintenance will be required. Even if the luminaires are NOT in use, maintenance will still be needed given its location (exterior use). The use of a durable type of wax on the chassis is recommended since it will help prevent contaminant build up. Inspect both power and data lines for any signs of contaminants or corrosion. Periodically reapplying di-electric grease, especially in coastal environments. If any signs of corrosion/contaminants are present, clean thoroughly, and/or replace connectors, then reapply di-electric grease. Typically, this should be done annually, or any time an opportunity presents itself. As a preventive measure, annual replacement of both vent valves is recommended. The vent valve membrane can become contaminated and/or clogged causing improper venting of humidity within the luminaire. Inspect all mounting hardware as a precaution.

Interior Maintenance: Inspect the interior every 30-days. The unit must be powered off/disconnected.

- Inspect zoom/focus mechanism, clean optics, lubricate linear bearings (Krytox oil) as needed, inspect belts for wear
- Inspect all rotating effect wheels, manually rotate them, note any resistance
- Inspect all remaining rotating belts for any wear
- Inspect all fans, clean as needed, check rotation, check connections
- Inspect CMY module, manually move flags and check for signs of resistance, and if needed, clean guide rods first, then reapply a thin layer of grease (moly lube)
- Clean interior with low-volume compressed air, then clean optics prior to reassembly of head covers

Although the base has limited moving parts, the pan belt should also be inspected for wear. Remember to always perform an IP test anytime a cover is removed.

There is no specific time frame regarding the routine replacement of parts such as belts/stepper motors, PCBs, or LEDs. These items should only be replaced on an as needed bases, except for cooling fans, which should be replaced once the luminaries reach 10,000-hours. This is a prophylactic measure intended to keep the unit running as cool as possible, insuring proper function of all internal components. A complete service breakdown is available, please contact service@adj.com for any needed parts or manuals.

SAFETY PRECAUTIONS



HIGH INTENSITY ULTRAVIOLET LIGHT



**AVOID DIRECT EYE & SKIN EXPOSURE.
WEAR PROPER EYE & SKIN PROTECTION.
SEE MANUAL FOR SAFETY INSTRUCTIONS.**

RISK GROUP 3 - RISK OF EXPOSURE TO ULTRAVIOLET UV RADIATION!

FIXTURE EMITS HIGH INTENSITY WAVELENGTH OF ULTRAVIOLET UV LIGHT FROM THE UV COLOR FILTER.

WEAR PROPER EYE AND SKIN PROTECTION. AVOID PROLONGED PERIODS OF EXPOSURE TO UV COLOR FILTER.

AVOID WEARING WHITE COLOR CLOTHING AND/OR USING UV PAINTS ON SKIN. AVOID DIRECT EYE AND/OR SKIN EXPOSURE AT DISTANCES LESS THAN 11 feet (3.3m).

DO NOT OPERATE FIXTURE WITH DAMAGED/MISSING EXTERNAL COVERS.

DO NOT LOOK DIRECTLY INTO THE UV LIGHT AND/OR VIEW UV LIGHT DIRECTLY WITH OPTICAL INSTRUMENTS THAT MAY CONCENTRATE THE LIGHT/RADIATION OUTPUT.

INDIVIDUALS SUFFERING FROM A RANGE OF EYE CONDITIONS, SUNLIGHT EXPOSURE DIS-ORDERS, OR INDIVIDUALS USING PHOTSENSITIVE MEDICATION, MAY RECEIVE DISCOMFORT IF EXPOSED TO THE ULTRAVIOLET UV LIGHT EMITTED FROM THE UV LED.

SAFETY PRECAUTIONS



PROTECTION CLASS 1 - FIXTURE MUST BE PROPERLY GROUNDED.



THERE ARE NO USER SERVICEABLE PARTS INSIDE THIS UNIT. DO NOT ATTEMPT ANY REPAIRS YOURSELF, AS DOING SO WILL VOID YOUR MANUFACTURER'S WARRANTY. DAMAGES RESULTING FROM MODIFICATIONS TO THIS FIXTURE AND/OR THE DISREGARD OF SAFETY INSTRUCTIONS AND GUIDELINES IN THIS MANUAL VOID THE MANUFACTURER'S WARRANTY AND ARE NOT SUBJECT TO ANY WARRANTY CLAIMS AND/OR REPAIRS.



**NEVER LOOK DIRECTLY INTO THE LIGHT SOURCE!
RETINA INJURY RISK - MAY INDUCE BLINDNESS!
SENSITIVE PERSONS MAY SUFFER AN EPILEPTIC SHOCK!**

- **Maximum ambient operating temperature is -4°F to 113°F (-20°C to 45°C)!**
- DO NOT TOUCH the fixture housing during operation. Disconnect the power and allow approximately 15 minutes for the fixture to cool down before servicing.
- DO NOT shake the fixture, and avoid brute force when installing and/or operating the fixture.
- DO NOT operate the fixture if the power cord has become frayed, crimped and/or damaged. If the power cord is damaged, replace immediately with a new one of the same power rating.
- DO NOT attempt to remove or break off the ground prong from the electrical cord. This prong is used to reduce the risk of electrical shock and fire in case of an internal short.
- DO NOT attempt to operate this unit if it has been damaged in any way.
- Disconnect from main power before making any type of connection.
- DO NOT block any air ventilation slots. All fan and air inlets must remain clean and never blocked. Allow approx. 6" (15cm) between fixture and other devices or a wall for proper cooling.
- Always be sure to mount this unit in an area that will allow proper ventilation. Allow about 6" (15cm) between this device and a wall.
- DO NOT remove the cover for any reason.
- When installing fixture in a suspended environment, always use mounting hardware that is no less than M10 x 25mm, and always install fixture with an appropriately rated safety cable.
- Never plug this unit in to a dimmer pack.
- During long periods of non-use, disconnect the unit's main power.
- Always mount this unit in safe and stable matter.
- Power-supply cords should be routed so that they are not likely to be walked on or pinched by items placed upon or against them, paying particular attention to the point where they exit from the unit.
- Cleaning - The fixture should be cleaned only as recommended by the manufacturer.
- Heat - The appliance should be situated away from heat sources such as radiators, heat registers, stoves, or other appliances (including amplifiers) that produce heat.
- The fixture should be serviced by qualified service personnel when:
 - A. The power-supply cord or the plug have been damaged.
 - B. Objects have fallen onto, or liquids have been spilled into, the fixture.
 - C. The fixture does not appear to operate normally or exhibits a marked change in performance.
 - D. The fixture has fallen and/or has been subjected to extreme handling.

BATTERY WARNINGS

HANDLING PRECAUTIONS

Do not short circuit the battery. Avoid subjecting the battery to a short circuit, as doing so generates a very high current, resulting in overheating, electrolyte gel leakage, harmful fumes, explosion risk, or other damage to the battery.

Mechanical shock. Dropping, impacting, striking, or bending the unit, or subjecting the unit to any other types of mechanical shock may cause failure or shortend life of the battery.

Do not disassemble the batteries. Never disassemble the batteries, as doing so may result in an internal short circuit in the battery, leading to fire, explosion, release of harmful fumes, or other hazards. Electrolyte gel is harmful, and contact should be avoided whenever possible. Should the electrolyte gel come into contact with the skin or eyes, flush the area of contact immediately with fresh water and seek medical attention immediately.

Do not expose battery to heat or fire. Never incinerate or dispose of the batteries in fire, as this could result in an explosion.

Do not exposure the battery to water or liquids. Never expose or immerse the batteries in liquids of any type, including water, seawater, soft drinks, juices, coffee, or other beverages.

Battery Replacement. For battery replacement please contact customer support.

Never use a damaged battery. Shipping carries a risk of damage to the battery. Should damage be observed, including damage to the plastic casing of the battery, deformation of the battery package, chemical or electrolyte odor, or leakage of the electrolyte gel, or any other miscellaneous damage, **DO NOT use the battery.** A battery with a odor of electrolyte or a gel leakage should be placed away from fire to avoid risk of fire or explosion.

Battery Storage. The battery should be stored at room temperature, with a charge of at least 50%. During long periods of storage, it is recommended that the battery be charged every 6 months. Doing so will prolong the life of the battery and will also make sure that the battery charge does not fall below the 30% mark.

Other Chemical Reactions. Because batteries rely on a chemical reaction to work, battery performance will deteriorate over time, even if stored for a long period of time without being used. In addition, if various usage conditions (such as charge, discharge, ambient temperature, etc.) are not maintained within the specified ranges, the life expectancy of the battery maybe shortened or the device in which the battery is used may be damaged by electrolyte gel leakage. If the batteries cannot maintain a charge for long periods of time, even when they are charged correctly, this may indicate the need to replace the battery.

Battery Disposal. Please dispose of battery according to local regulations.

BATTERY CHARGING

The fixture may be charged directly using AC power, or using the optional charging base and power supply (sold separately). Connect the power supply to a power source on one end, and to the charging base on the other, then slot the fixture onto the charging base with the charging port side facing downwards. Refer to the image below.

It is recommended to disconnect the unit from the charger once the battery has reached full charge. Doing so reduces the risk of overcharging the battery, which can shorten the service life of the battery.

Please note that the charging components are NOT protected against the intrusion of dust and/or water, and are intended for use only in a dry indoor environment. Do NOT expose to rain or moisture. When charging is complete, always seal the charging port with the included plug to maintain the fixture's IP rating.

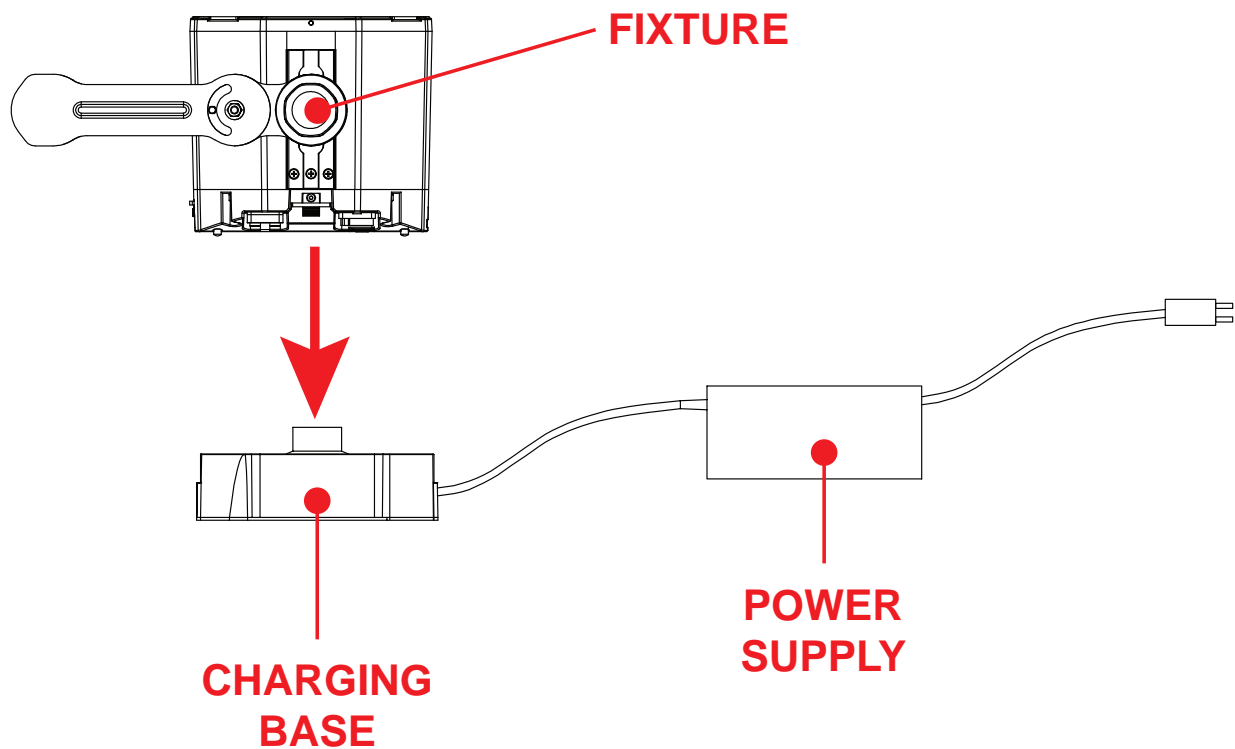

OVERVIEW

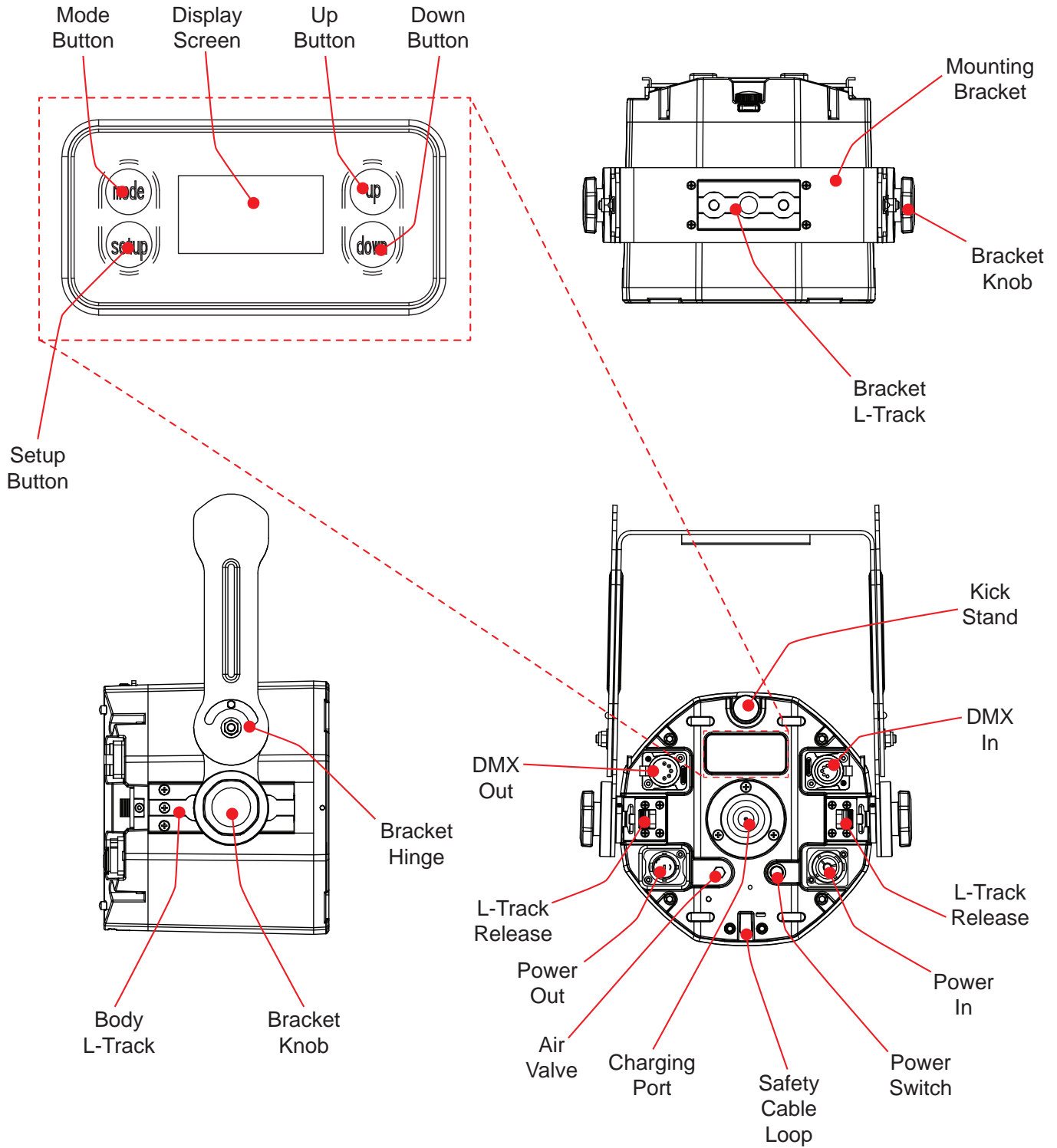

INSTALLATION GUIDELINES



DO NOT INSTALL THE FIXTURE IF YOU ARE NOT QUALIFIED TO DO SO!

Fixture **MUST** be installed following all local, national, and country commercial electrical and construction codes and regulations.

When installing the unit, the trussing or area of installation must be able to hold 10 times the weight of the unit and any attached accessories without any deformation. The unit must be secured with a secondary safety attachment, e.g. an appropriately-rated safety cable.

Before rigging/mounting a single fixture to any metal truss/structure or placing the fixture(s) on any surface, a professional equipment installer **MUST** be consulted to determine if the metal truss/structure or surface is properly certified to safely hold the combined weight of the fixture(s), clamps, cables, and accessories.

Ambient operating temperature range is **-4°F to 113°F (-20°C to 45°C)**. Do not operate this device when ambient temperature falls outside this range!

Fixture(s) should be installed away from walking paths, seating areas, or areas where unauthorized personnel might reach the fixture by hand.

NEVER stand directly below the fixture(s) when rigging, removing, or servicing.

Overhead fixture installation must always be secured with a secondary safety attachment, such as an appropriately rated safety cable that can hold 10 times the weight of the fixture.

Overhead mounting requires extensive experience, including calculating working load limits, knowledge of installation material being used, and periodic safety inspection of all installation material as well as the unit itself. If you lack these qualifications, do not attempt the installation yourself.

The installation should be checked by a skilled person once a year.

Please note that this device features an alarm system that, if set and activated, will be triggered by any movement of the device, including knocking over the device. The alarm will sound and the device will strobe red for the amount of time that was set in the “Alarm Time” setting, but will automatically stop when the device is returned to its place. Please be aware of this feature in the event that you decide to re-locate or re-position the device after the initial setup!

INSTALLATION GUIDELINES

CLAMP MOUNTING

When mounting the fixture to a truss or any other suspended structure, be sure to secure an appropriately rated clamp to the hole on the top of the mounting bracket. Insert a bolt of appropriate size through the bottom of the mounting clamp and the hole on the mounting bracket, and secure them together with a matching nut. Additionally, a safety cable of the appropriate weight rating should be secured through the safety cable loop on the rear of the unit.

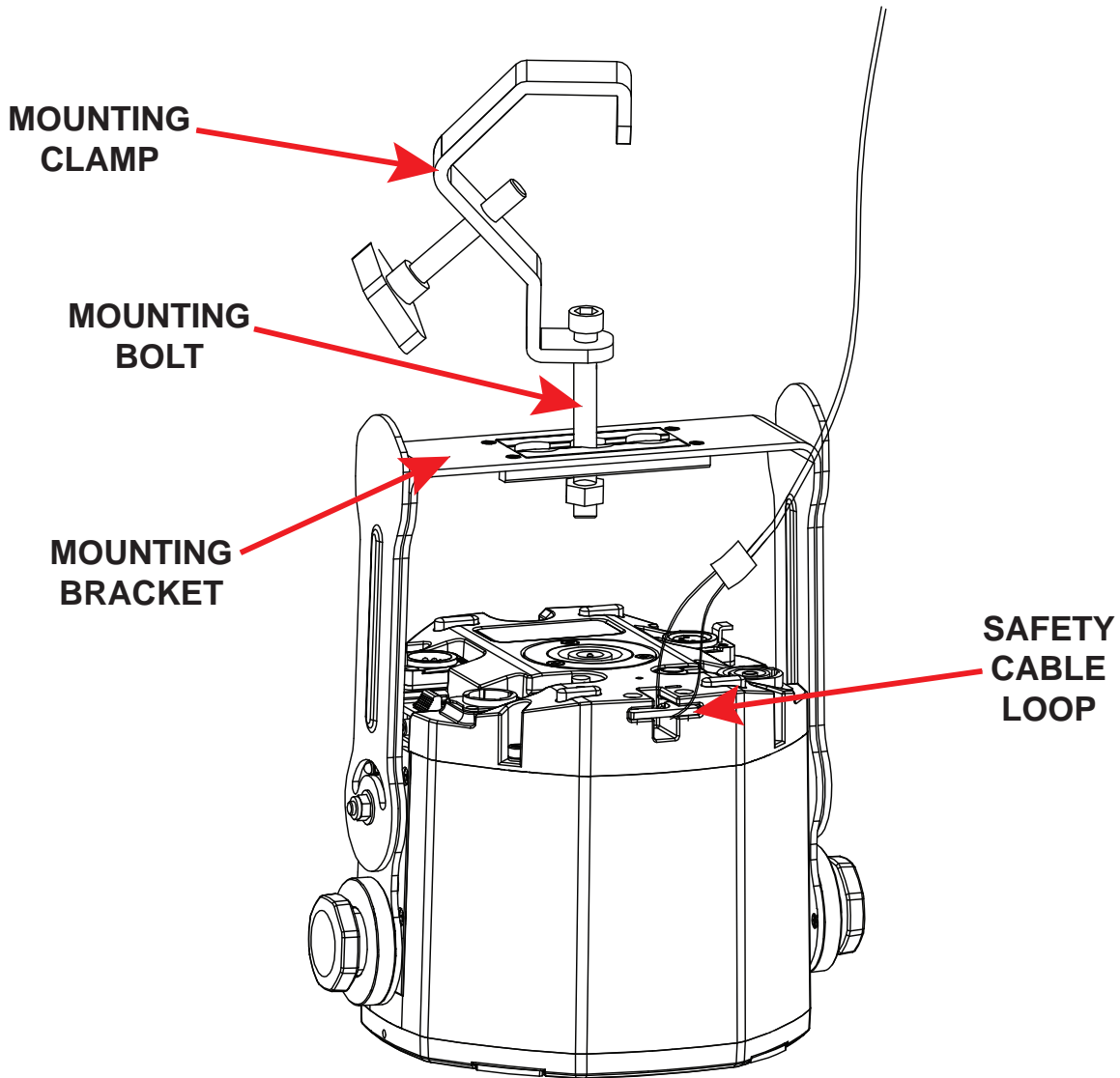

SAFETY CABLE:

ALWAYS ATTACH A SAFETY CABLE WHENEVER INSTALLING THIS FIXTURE IN A SUSPENDED ENVIRONMENT TO ENSURE THAT THE FIXTURE WILL NOT FALL IF THE CLAMP FAILS.

INSTALLATION GUIDELINES

STAND MOUNTING

This unit can also be installed atop a tripod stand. Simply secure the Omega bracket to the bottom face of the device, then insert the threaded bolt on the top of the tripod stand through the hole in the Omega bracket. Tighten the nut onto the threaded bolt to secure the mounted device in place.

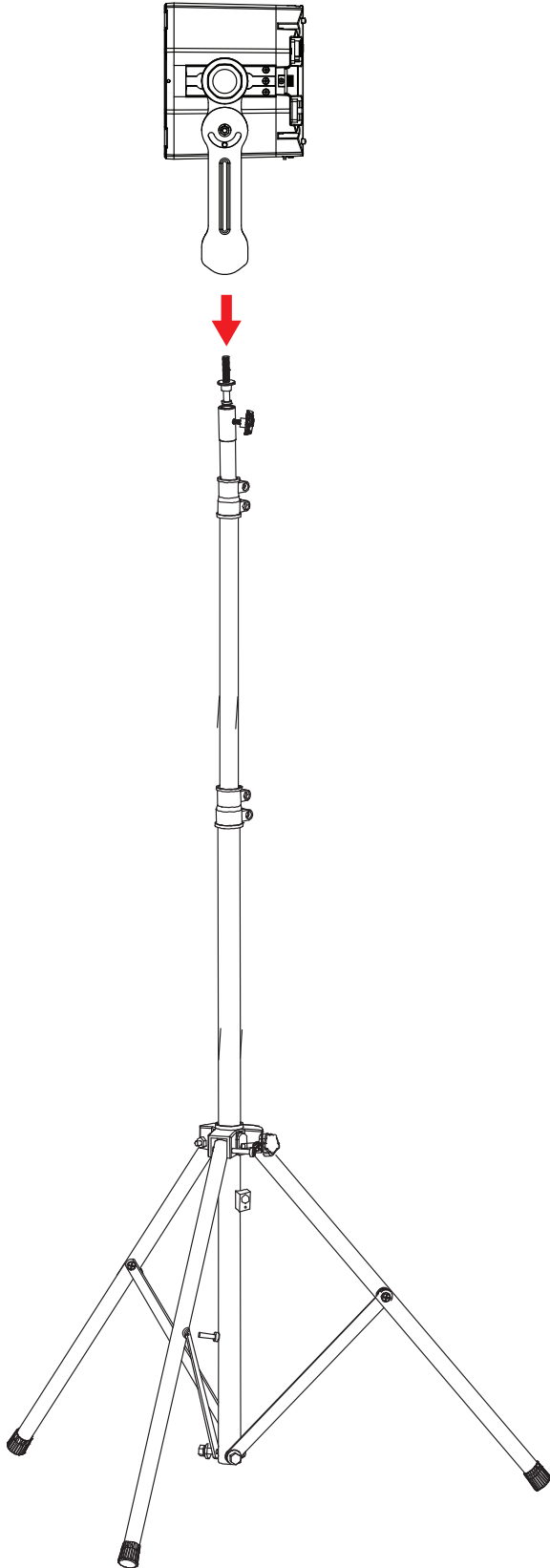

CAUTION!

MAKE SURE THAT THE TRIPOD LEGS AND ALL TELESCOPING ELEMENTS OF THE TRIPOD STAND ARE LOCKED IN PLACE BEFORE INSTALLING THE DEVICE ATOP THE STAND!

**POSITION THE TRIPOD STAND AND MOUNTED DEVICE ONLY ON FLAT, STABLE SURFACES!
DEPLOY TRIPOD LEGS FULLY IN ORDER TO MAXIMIZE STABILITY!**

INSTALLATION GUIDELINES

POTENTIAL INTERNAL FIXTURE DAMAGE FROM EXTERNAL SOURCES OF LIGHT BEAMS

External sources of light beams from direct sunlight, lighting moving head fixtures, and lasers, which are focused directly towards the exterior housing and/or penetrate the front lens opening of ADJ lighting fixtures, can cause severe internal damage including burning to optics, dichroic color filters, glass and metal gobos, prisms, animation wheels, frost filters, iris, shutters, motors, belts, wiring, discharge lamps, and LEDs.

This issue is not specific only to ADJ lighting fixtures, it is a common issue with lighting fixtures from all manufacturers. Although there is no true way to fully prevent this issue from happening, the guidelines below can prevent any potential damage from occurring if followed. Contact ADJ Service for more details.

DO NOT EXPOSE THE FIXTURE AND/OR FRONT LENS OPENING TO LIGHT BEAMS FROM DIRECT SUNLIGHT, OTHER LIGHTING MOVING HEAD FIXTURES, AND LASERS WHILE UNPACKING, INSTALLATION, USE, AND EXTENDED IDLE TIMES OUTDOORS. DO NOT FOCUS A LIGHT BEAM FROM ONE LIGHTING FIXTURE DIRECTLY TOWARDS ANOTHER.

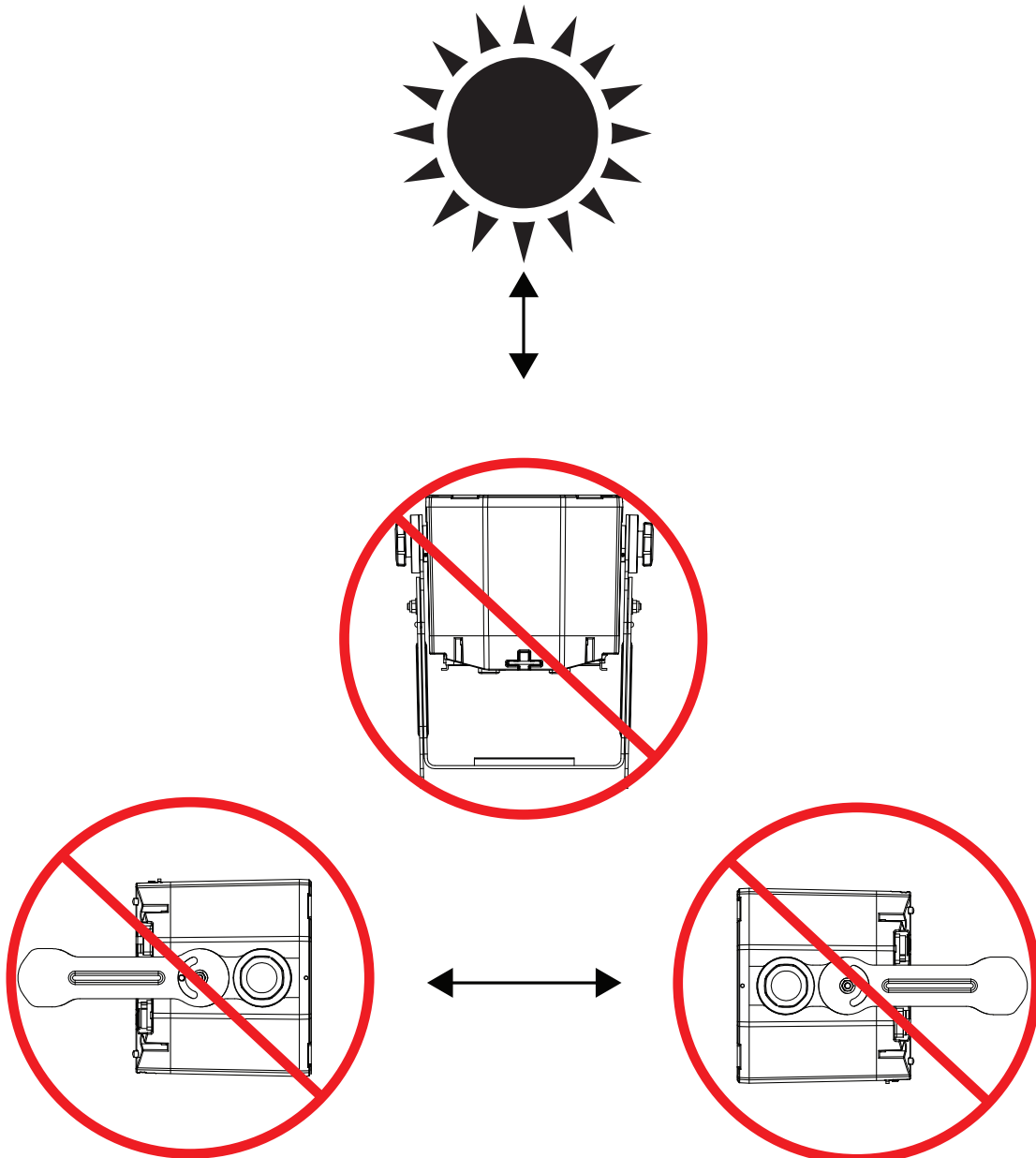

INSTALLATION GUIDELINES

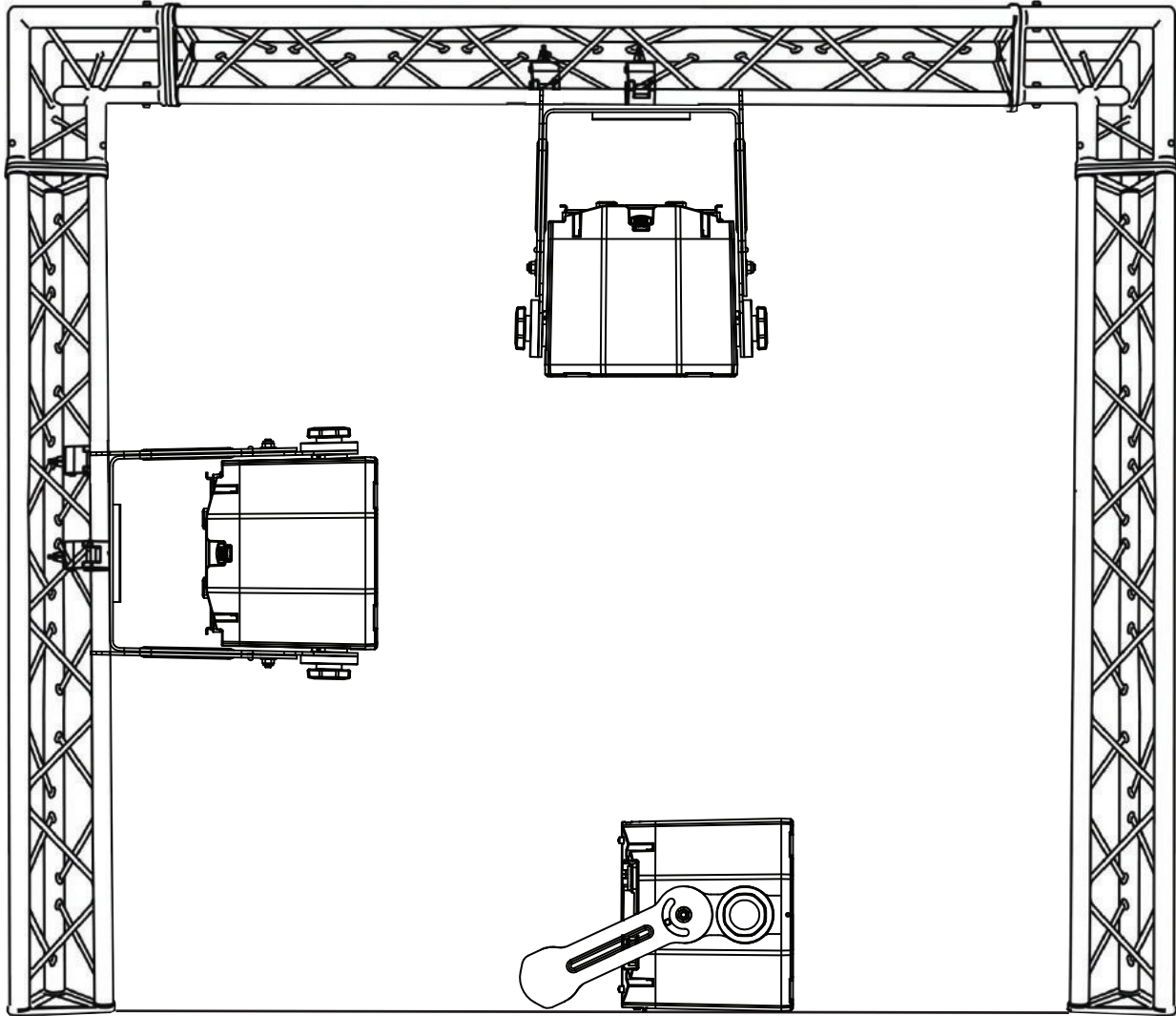

The unit is fully operational in three different mounting positions: hanging upside-down from the ceiling or trussing, sideways on trussing, or set on a flat level surface. Be sure this fixture is kept at least 12m (40ft) away from any flammable materials (decorations, etc). Always use and install a safety cable (not included) as a safety measure to prevent accidental damage and/or injury in the event the clamp fails. Never use the carrying handles for secondary attachment.



FALLING FIXTURES CAN CAUSE SEVERE INJURY OR SERIOUS EQUIPMENT DAMAGE! FOR THIS REASON, FIXTURES SHOULD BE INSTALLED AND INSPECTED ONLY BY QUALIFIED PERSONNEL. DO NOT INSTALL THE UNIT IF YOU LACK THE QUALIFICATIONS TO DO SO, OR IF YOU HAVE DOUBTS ABOUT THE SAFETY AND SECURITY OF THE INSTALLATION SETUP OR LOCATION!



ALWAYS ATTACH A SAFETY CABLE WHENEVER INSTALLING THIS FIXTURE IN A SUSPENDED ENVIRONMENT TO ENSURE THAT THE FIXTURE WILL NOT FALL IF THE CLAMP FAILS.



IF THE UNIT IS FITTED WITH THE OPTIONAL GEL FRAME OR BARNDOORS, THE UNIT MUST BE INSTALLED WITH THE LATCH FACING UPWARD TO ENSURE THAT THESE ACCESSORIES DO NOT FALL IF THE LATCH FAILS.

ACCESSORY INSTALLATION

GEL HOLDER

1. Lower the Gel Holder onto the fixture's lens frame. Pull out on the two gel holder pin tabs, then rotate the Gel Holder into place so that the pin tabs align with the matching holes on the fixture. Release the pin tabs to lock the Gel Holder in place.

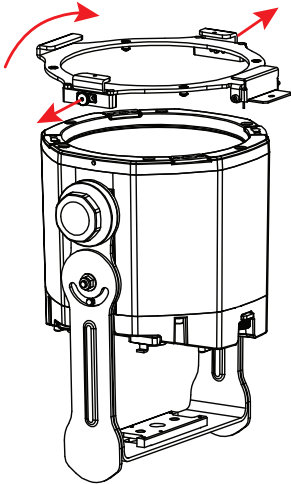

2. Flip open the frame latch, and insert the Gel Frame into the Gel Holder.

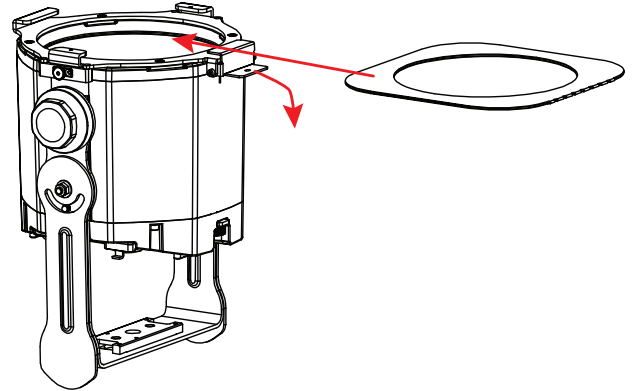

3. Insert the Barndoors into the Gel Holder, making sure that the Barndoors lie on top of the Gel Frame.

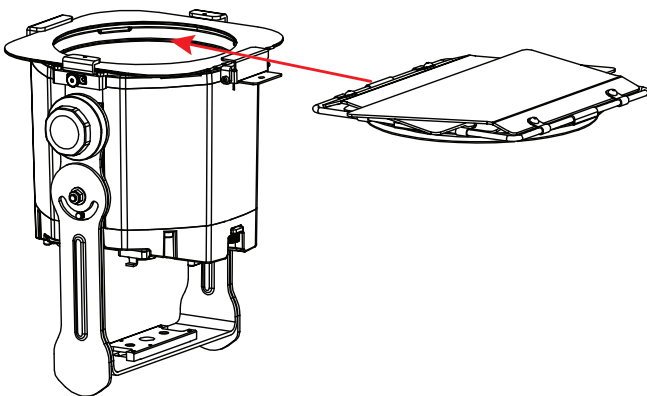

4. Close the frame latch to secure both the Gel Frame and the Barndoors in place. **Please note that the unit should be installed with the latch facing upward to ensure that the accessories do not fall in the event that the latch fails.**

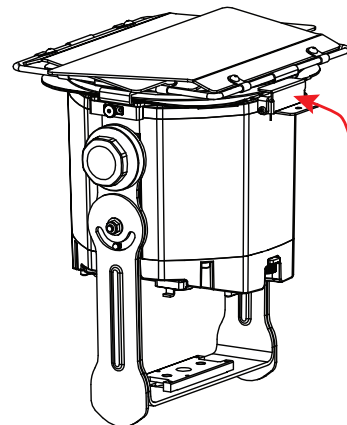

ACCESSORY INSTALLATION

EPIX P7 SNOOT

1. Loosen the 2x Thumb Screws on the collar of the Epix FX Snoot, then place the Snoot on the lens frame of the fixture.

2. With the Epix FX Snoot in place, secure the 2x Thumb Screws.

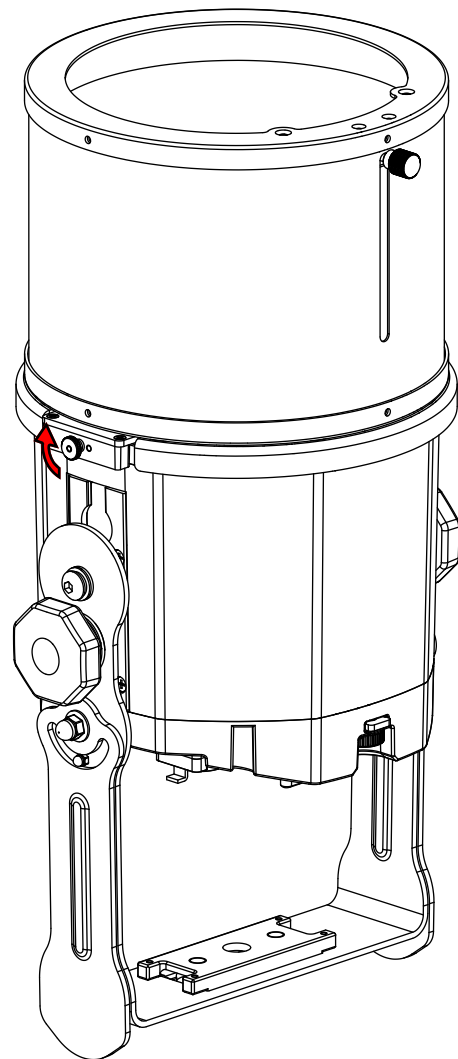
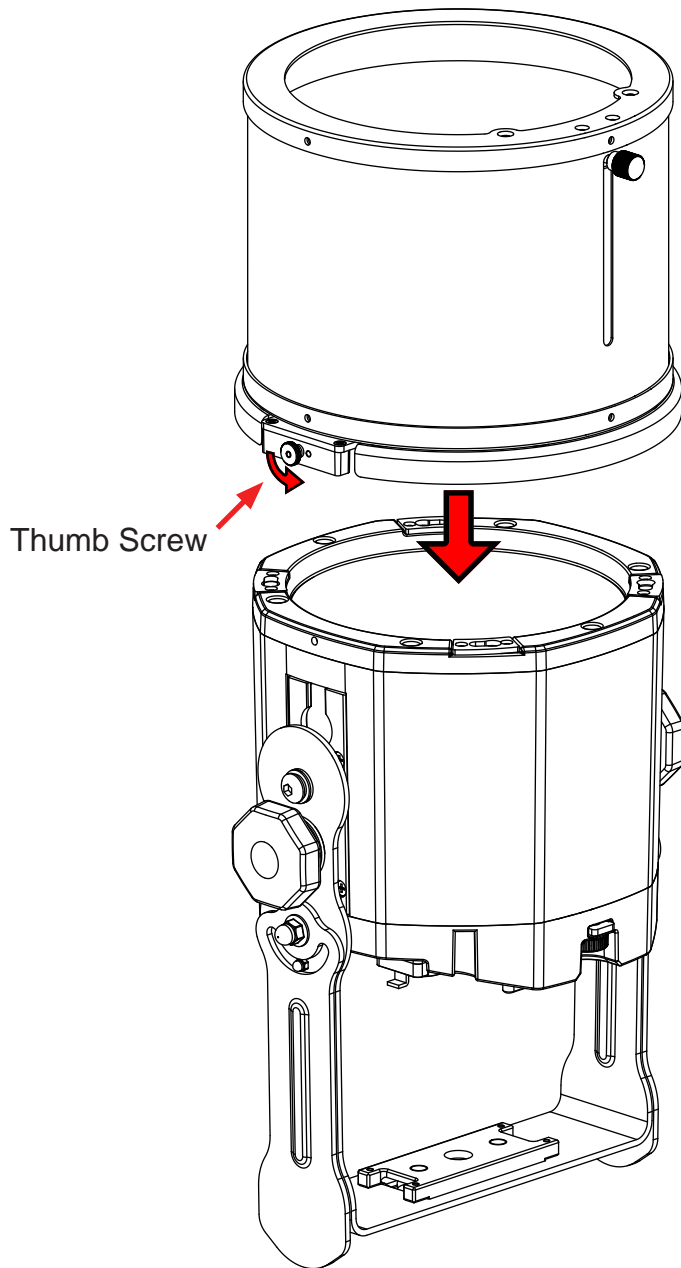

ACCESSORY INSTALLATION

L-TRACK MOUNTING

Alternately, this unit's L-track mounting system allows the user to slide the mounting clamps along the tracks and lock them down in the desired position. The L-tracks are located on the mounting bracket and along the sides of the unit's body. Special L-track mounting clamps, which incorporate an L-track attachment rail in place of a mounting bolt hole, are available in both regular and extended lengths. Similarly, L-track adapters are also available which can be fitted to any standard mounting clamp.

To attach an L-track clamp or adapter, simply insert the attachment rail into the matching track on the fixture, slide to its desired location, and tighten the fastener knob on the attachment to secure in place.

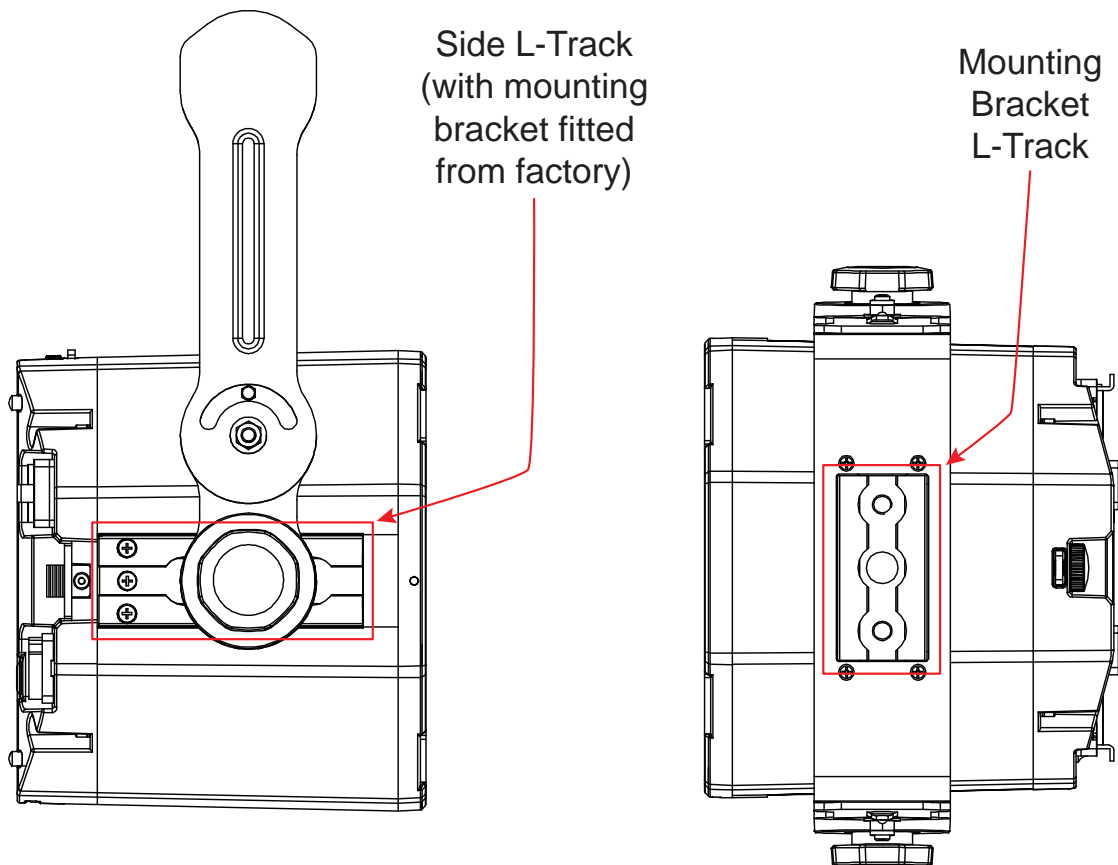
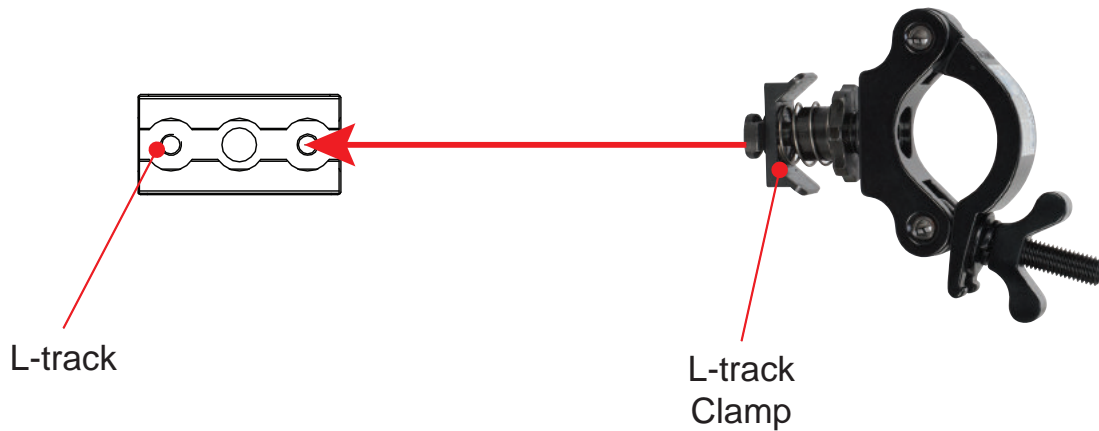

REMOTE DEVICE MANAGEMENT (RDM)

NOTE: In order for RDM to work properly, RDM enabled equipment must be used throughout the entire system, including DMX data splitters and wireless systems.

Remote Device Management (RDM) is a protocol that sits on top of the DMX512 data standard for lighting, allowing the DMX systems of the fixtures to be modified and monitored remotely. This protocol is ideal for instances in which a unit is installed in a location that is not easily accessible.

With RDM, the DMX512 system becomes bi-directional, allowing a compatible RDM enabled controller to send out a signal to devices on the wire, as well as allowing the fixture to respond (known as a *GET* command). The controller can then use its *SET* command to modify settings that would typically have to be changed or viewed directly via the unit's display screen, including the DMX Address, DMX Channel Mode, and Temperature Sensors.

FIXTURE RDM INFORMATION:

RDM Code	Device ID	Device Model ID	Personality ID
1900	000000-FFFFFF	2507	5Ch (1); 6Ch (2); 9Ch (3); 13Ch (4); 22Ch (5); 24Ch (6); 42Ch (7); 45Ch (8); 60Ch (9)

Please be aware that not all RDM devices support all RDM features, and therefore it is important to check beforehand to ensure that the equipment that you are considering includes all of the features that you require.

[0x0001] Disc Unique Branch
[0x0002] Disc Mute
[0x0003] Disc Un Mute
[0x0050] Supported Parameters
[0x0060] Device Info
[0x0081] Manufacturer Label
[0x0082] Device Label
[0x00C0] Software Version Label
[0x00E0] DMX Personality
[0x00F0] DMX Start Address
[0x0201c] Sensor Value
[0x0343] Curve
[0x0344] Curve Description
[0x1000] Identify Device
[0x0141] DMX Fail Mode

SYSTEM MENU

This unit features a display screen with a 4-button control pad, which can be used to easily adjust any device settings.

Pressing the MODE button will cycle through the various Main Menu options. When the desired Main Menu option is displayed on the screen, press the SETUP button to enter the sub-menu, then use the UP and DOWN buttons to scroll through sub-menu options. In some cases, there will be a second sub-menu that can be navigated in the same way.

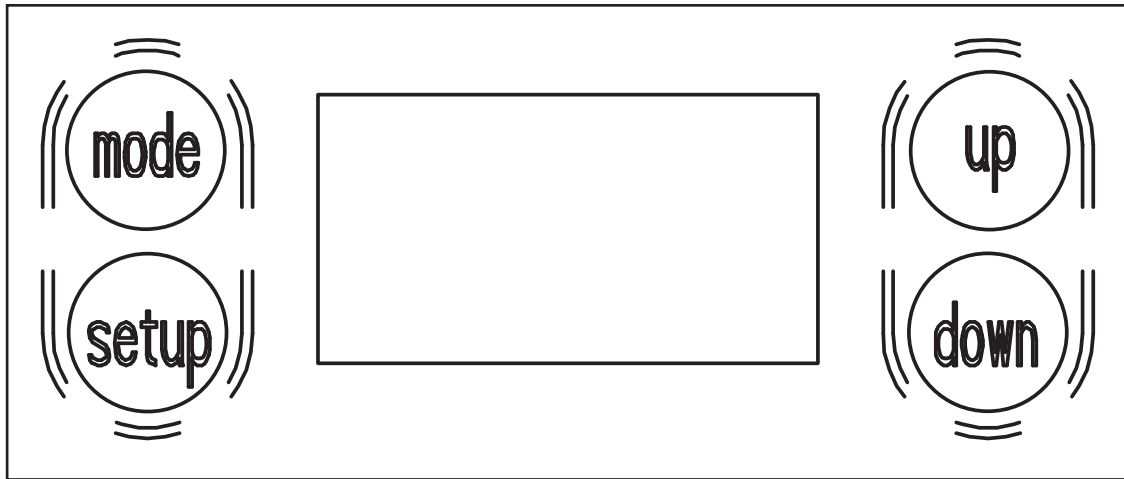

SCREEN LOCK

The control panel screen will lock after a period of inactivity, which is set to 30 seconds by default. This setting can be changed by navigating to Personality > Display > Touch Screen Lock in the system menu. To unlock the screen, press and hold any spot on the display screen for 3 seconds.

SYSTEM MENU

DMX SETTINGS	DMX Address	001 - 512		Set DMX address	
	DMX Channel Mode	5ch		Select DMX channel mode	
		6ch			
		9ch			
		13ch			
		22ch			
		24ch			
		42ch			
		45ch			
	60ch				
No DMX Status	Hold Last		Fixture holds last settings received if DMX signal is lost		
	Blackout		Fixture takes all parameters to zero if DMX signal is lost		
	Manual Settings		Fixture defaults to preset manual settings if DMX signal is lost		
	Internal Programs		Fixture defaults to preset internal program if DMX signal is lost		
PERSONALITY	Prim / Sec Mode	Primary / Secondary		Set unit as a primary or a secondary	
	Select Signal	DMX or Aria		Select signal source	
		Enable Aria In and Physical DMX Out	On / Off		
	Aria Settings	Enable Aria	On / Off		Enable or disable Aria
		Frequency	900 Mhz / 2.4 Ghz		Select operating frequency for Aria
		Aria 2.4Ghz Channel	00 - 15		Select Aria channel for 2.4Ghz
		Aria 900Mhz Channel	00 - 09		Select Aria channel for 900Mhz
		Mesh	On / Off		Enable or disable Aria mesh
		Bluetooth Enable	On / Off		Enable or disable Bluetooth
RDM	On / Off		Enable or disable RDM		

SYSTEM MENU

PERSONALITY (continued)	Dim Modes	Standard		Set dim mode and dim delay time	
		Stage			
		TV			
		Architectural			
		Theatre			
		Stage 2			
		Dim Delay	0 - 99		
	Dim Curve	Square		Select dim curve	
		Linear			
		Inv Squa			
		S Curve			
	IR Function	On / Off		Enable or disable remote control	
	IR Button Colors	Button 0	Red	000 - 255	Configure color settings for IR remote buttons
			Green	000 - 255	
			Blue	000 - 255	
			Amber	000 - 255	
			Lime	000 - 255	
			UV	000 - 255	
		
		Button 15	Red	000 - 255	
Green			000 - 255		
Blue			000 - 255		
Amber			000 - 255		
Lime			000 - 255		
UV	000 - 255				
Pixel Flip	Pixel Flip 1		Select pixel flip mode		
	Pixel Flip 2				
	Pixel Flip 3				
	Pixel Flip 4				
LED Refresh	900, 1000, 1100, 1200 , 1300, 1400, 1500, 2500, 4000, 5000, 10k, 15k, 20k, 25k		Set LED refresh frequency		
Display	Screen Saver Delay	Off, 1 - 10 sec		Screen goes to sleep after selected period of inactivity	
	Touch Screen Lock	Off - 30sec , 1 min		Screen locks after selected period of inactivity	
	Rotate Display 180°	Yes / No		Flip display screen orientation	
Language	Passcode = 050	English / Spanish		Select language	
Alarm	Passcode = 011	On / Off		Unit alarm trips when unit is moved	
		Alarm Time	10s , 20s, 30s, 40s, 60s		

SYSTEM MENU

PERSONALITY (continued)	Service	Passcode = 050	White Balance	Red 000 - 255	Effect adjustment
				Green 000 - 255	
				Blue 000 - 255	
				Amber 000 - 255	
				Lime 000 - 255	
			UV 000 - 255		
Color Calibration	Enable / Disable	When disabled, unit outputs full potential for all RGBAL+UV colors			
DMX Indicators	Enable / Disable	Enable or disable DMX indicators			
Charging Indicators	Enable / Disable	Enable or disable charging indicators			
Factory Restore	Yes / No	Return unit to factory default settings			
MANUAL CONTROL	Red	000 - 255	Manually configure each parameter		
	Green	000 - 255			
	Blue	000 - 255			
	Amber	000 - 255			
	Lime	000 - 255			
	UV	000 - 255			
	RGBAL+UV Color Macros	000 - 064			
	Background Red	000 - 255			
	Background Green	000 - 255			
	Background Blue	000 - 255			
	RGB Background Color Macros	000 - 064			
	Color Temperature Linear	No Function, 2300K - 9900K			
	Color Temp Pre-sets	No Function, 2300K, 2400K, 2500K....9900K			
	Shutter	000 - 255			
	Dimmer	000 - 255			
	Internal Programs	Off , Prog 0, Prog 1....Prog 13			
Internal Programs Speed	000 - 255, default = 127				
Internal Programs Fade	000 - 255				

SYSTEM MENU

MANUAL CONTROL (continued)	RGB Background Programs	000 - 255		Manually configure each parameter
	RGB Background Programs Speed	000 - 255		
	RGB Background Programs Fade	000 - 255		
INTERNAL PROGRAMS	Program 0	Speed	1 - 255, default = 127	Select and configure internal programs
		Fade	0 - 255, default = 0	
	Program 1	Speed	1 - 255, default = 127	
		Fade	0 - 255, default = 0	
	
	Program 13	Speed	1 - 255, default = 127	
Fade		0 - 255, default = 0		
INFORMATION	LED Temperature	xxx F / xxx C		Display current temperature
	Software Version	x.xx		Display current software version
	RDM UID	xxxxxx		Display current RDM universe ID
BATTERY	Charging Time	xx hours		Time left til full charge
	Current Life	xxx%		Remaining battery charge
	Operation Mode	5 Hr - 20 Hr		Select battery mode. <i>Please note that the light output will decrease as time goes on in order to conform to the selected run time.</i>

UC IR REMOTE

This unit can be operated using the ADJ UC IR24 remote control. **The unit can only be controlled when it has been set to Primary mode. The unit will NOT respond to commands when it has been set to Secondary mode.** When using the UC IR to control multiple units that are operating in primary/secondary mode, follow these steps to set up the units:

1. Power on the unit, and press MODE to scroll to the “Personality” menu, then press SETUP.
2. Use the UP and DOWN buttons to scroll to “Prim/Sec Mode”. Press SETUP, then use the UP and DOWN buttons set the device to “Primary”. The unit will NOT respond to IR remote commands when it has been set to “Secondary” mode.
3. Press SETUP to confirm and return to the “Personality” menu.
4. Use UP and DOWN to scroll to “IR Function” and press SETUP.
5. Use the UP and DOWN buttons to scroll to “ON”, then press SETUP to confirm.

CONTROLS

- **On:** Fixture turns on and reverts to the last running state
- **Off:** Fixture goes into stand by mode in a blackout state.
- **Strobe:** Activates strobe mode. The strobe rate can be adjusted using the + / - buttons.
- **Sound:** This button has no defined function for this unit.
- **Color:** Activates color mode. Select a static color (0-15) using the number keys. The intensity for the set color can then be adjusted with the +/- buttons.
- **Program:** Activates program mode. Select an internal program (0-15) using the number keys. The selected program run speed can be adjusted with the +/- buttons. *Note: 13 of the 15 buttons will activate a program for this unit.*
- **+ and - buttons:** Adjusts strobe rate, mic sensitivity, intensity, or program run speed. The +/- buttons can be repeatedly pressed to increase or decrease by individual level increments, or pressed and held to quickly make large adjustments at once.
- **Number Keys (0-15):** These buttons are used to select preset static colors and internal programs. Colors stored in the number keys can be edited from the units menu if desired.



IR DEFAULT VALUES

BUTTON	RED	GREEN	BLUE	AMBER	LIME	UV
0	255	255	255	255	0	0
1	255	0	0	0	0	0
2	0	255	0	0	0	0
3	0	0	255	0	0	0
4	255	46	0	0	0	0
5	0	255	28	0	0	0
6	17	0	75	0	0	0
7	255	83	0	63	0	0
8	0	255	52	0	0	0
9	32	0	75	22	0	0
10	0	0	0	255	0	0
11	0	114	160	0	0	0
12	100	0	97	0	0	0
13	255	255	0	255	0	0
14	0	75	136	0	0	0
15	146	0	80	0	0	0

EDITING IR BUTTON VALUES

These fixtures allow the user to create custom RGBAL+UV values and assign them to the numbered keys (0-15) on the remote control. Follow the steps below:

1. In the main system menu, press MODE to navigate to “Personality,” then press SETUP. Use the UP and DOWN buttons to scroll to “IR Button Colors,” then press SETUP again.
2. Use the UP and DOWN buttons to scroll to the number of the remote button that you would like to use. Options range from “Button 0” to “Button 15.” Press SETUP to select the button shown on the display screen.
3. Create a custom color for the button you have selected by using the UP and DOWN buttons to scroll through the color component options (Red, Green, Blue, Amber, Lime, or UV). Press SETUP to select a color component option, then use the UP and DOWN buttons to adjust the intensity of that color component option. Selectable values range from 000 to 255. Repeat this process until you have set the desired Red, Green, Blue, Amber, Lime, and UV intensities to create your custom color.

NOTE: Once you have created and assigned a custom RGBAL+UV value to a remote button, the default color for the remote button will be overridden. This means that the output color of the fixture may no longer resemble the color shown on the remote button. The only way to return to the default RGBAL+UV value is to reset the unit to the default factory settings by navigating to Personality > Service > Factory Restore.

NOTE: If multiple units have been linked in a primary-secondary set up, the custom RGBAL+UV values only need to be set up on the primary unit. The custom RGBA settings will carry over automatically to any secondary units in the system.L+UV

DMX SETUP

DMX-512: DMX is short for Digital Multiplex. This is a universal protocol used as a form of communication between intelligent fixtures and controllers. A DMX controller sends DMX data instructions from the controller to the fixture. DMX data is sent as serial data that travels from fixture to fixture via the DATA “IN” and DATA “OUT” XLR terminals located on all DMX fixtures (most controllers only have a DATA “OUT” terminal).

DMX Linking: DMX is a language allowing all makes and models of different manufacturers to be linked together and operate from a single controller, as long as all fixtures and the controller are DMX compliant. To ensure proper DMX data transmission, try to use the shortest cable path possible when linking several DMX fixtures. The order in which fixtures are connected in a DMX line does not influence the DMX addressing. For example, a fixture assigned a DMX address of 1 may be placed anywhere in a DMX line: at the beginning, at the end, or anywhere in the middle. When a fixture is assigned a DMX address of 1, the DMX controller knows to send DATA assigned to address 1 to that unit, no matter where it is located in the DMX chain.

Data Cable (DMX Cable) Requirements (For DMX Operation): This unit can be controlled via DMX-512 protocol. The DMX address is set on the rear panel of the unit. Your unit and your DMX controller require a standard 5-pin XLR connector for data input and data output. We recommend Accu-Cable DMX cables. If you are making your own cables, be sure to use standard 110-120 Ohm shielded cable (This cable may be purchased at almost all pro lighting stores). Your cables should be made with a male XLR connector at one end and a female XLR connector at the other. Also remember that DMX cable must be daisy chained and cannot be split.

Notice: Be sure to follow the illustration below when making your own cables. Do not use the ground lug on the XLR connector. Do not connect the cable’s shield conductor to the ground lug or allow the shield conductor to come in contact with the XLR’s outer casing. Grounding the shield could cause a short circuit and erratic behavior.

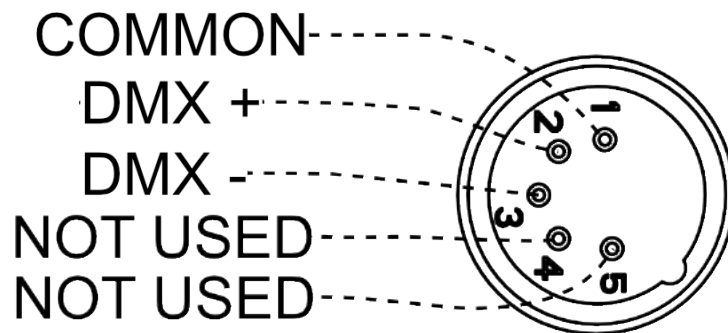

DMX SETUP

Special Note: Line Termination. When longer runs of cable are used, you may need to use a terminator on the last unit to avoid erratic behavior. A terminator is a 110-120 ohm 1/4 watt resistor which is connected between pins 2 and 3 of a male XLR connector (DATA + and DATA -). This unit is inserted in the female XLR connector of the last unit in your daisy chain to terminate the line. Using a cable terminator (ADJ part number Z-DMX/T) will reduce the risk of erratic behavior.

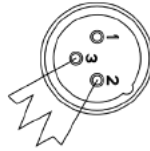
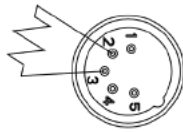

A DMX512 terminator reduces signal errors, avoiding most signal reflection interference. Connect PIN 2 (DMX-) and PIN 3 (DMX+) of the last fixture in series with a 120 Ohm, 1/4 W Resistor to terminate the DMX512.

DMX ADDRESSING.

All fixtures should be given a DMX starting address when using a DMX controller, so the correct fixture responds to the correct control signal. This digital starting address is the channel number from which the fixture starts to “listen” to the digital control signal sent out from the DMX controller. The assignment of this starting DMX address is achieved by setting the correct DMX address on the digital control display on the fixture.

You can set the same starting address for all fixtures or a group of fixtures, or set different addresses for each individual fixture. Setting all fixtures to the same DMX address will cause all fixtures to react in the same way. In other words, changing the settings of one channel will affect all the fixtures simultaneously.

If you set each fixture to a different DMX address, each unit will start to “listen” to the channel number you have set, based on the quantity of DMX channels of each fixture. That means changing the settings of one channel will only affect the selected fixture.

For example, when this unit is operating in 5 channel mode, you should set the starting DMX address of the first unit to 1, the second unit to 6 (1 + 5), the third unit to 11 (1 + 5 + 5), and so on. See the chart below for more details.

CHANNEL MODE	UNIT 1 ADDRESS	UNIT 2 ADDRESS	UNIT 3 ADDRESS	UNIT 4 ADDRESS
5 Ch	1	6	11	16
6 Ch	1	7	13	19
9 Ch	1	10	19	28
13 Ch	1	14	27	40
22 Ch	1	23	45	67
24 Ch	1	25	49	73
42 Ch	1	43	85	127
45 Ch	1	46	91	136
60 Ch	1	61	121	181

DMX TRAITS

CHANNEL									DMX VALUES	FUNCTION
5Ch	6Ch	9Ch	13Ch	22Ch	24Ch	42Ch	45Ch	60Ch		
	1	1		1	1				000 - 255	All Red , 0 - 100%
	2	2		2	2				000 - 255	All Green , 0 - 100%
	3	3		3	3				000 - 255	All Blue , 0 - 100%
	4	4		4	4				000 - 255	All Amber , 0 - 100%
	5	5		5	5				000 - 255	All Lime , 0 - 100%
	6	6		6	6				000 - 255	All UV , 0 - 100%
						1	1	1	000 - 255	Red 1 , 0 - 100%
						2	2	2	000 - 255	Green 1 , 0 - 100%
						3	3	3	000 - 255	Blue 1 , 0 - 100%
						4	4	4	000 - 255	Amber 1 , 0 - 100%
						5	5	5	000 - 255	Lime 1 , 0 - 100%
						6	6	6	000 - 255	UV 1 , 0 - 100%
						7	7	7	000 - 255	Red 2 , 0 - 100%
						8	8	8	000 - 255	Green 2 , 0 - 100%
						9	9	9	000 - 255	Blue 2 , 0 - 100%
						10	10	10	000 - 255	Amber 2 , 0 - 100%
						11	11	11	000 - 255	Lime 2 , 0 - 100%
						12	12	12	000 - 255	UV 2 , 0 - 100%
						13	13	13	000 - 255	Red 3 , 0 - 100%
						14	14	14	000 - 255	Green 3 , 0 - 100%
						15	15	15	000 - 255	Blue 3 , 0 - 100%
						16	16	16	000 - 255	Amber 3 , 0 - 100%
						17	17	17	000 - 255	Lime 3 , 0 - 100%
						18	18	18	000 - 255	UV 3 , 0 - 100%
						19	19	19	000 - 255	Red 4 , 0 - 100%
						20	20	20	000 - 255	Green 4 , 0 - 100%
						21	21	21	000 - 255	Blue 4 , 0 - 100%
						22	22	22	000 - 255	Amber 4 , 0 - 100%
						23	23	23	000 - 255	Lime 4 , 0 - 100%
						24	24	24	000 - 255	UV 4 , 0 - 100%
						25	25	25	000 - 255	Red 5 , 0 - 100%
						26	26	26	000 - 255	Green 5 , 0 - 100%
						27	27	27	000 - 255	Blue 5 , 0 - 100%
						28	28	28	000 - 255	Amber 5 , 0 - 100%
						29	29	29	000 - 255	Lime 5 , 0 - 100%
						30	30	30	000 - 255	UV 5 , 0 - 100%
						31	31	31	000 - 255	Red 6 , 0 - 100%
						32	32	32	000 - 255	Green 6 , 0 - 100%
						33	33	33	000 - 255	Blue 6 , 0 - 100%
						34	34	34	000 - 255	Amber 6 , 0 - 100%
						35	35	35	000 - 255	Lime 6 , 0 - 100%

DMX TRAITS

CHANNEL									DMX VALUES	FUNCTION
5Ch	6Ch	9Ch	13Ch	22Ch	24Ch	42Ch	45Ch	60Ch		
						36	36	36	000 - 255	UV 6 , 0 - 100%
						37	37	37	000 - 255	Red 7 , 0 - 100%
						38	38	38	000 - 255	Green 7 , 0 - 100%
						39	39	39	000 - 255	Blue 7 , 0 - 100%
						40	40	40	000 - 255	Amber 7 , 0 - 100%
						41	41	41	000 - 255	Lime 7 , 0 - 100%
						42	42	42	000 - 255	UV 7 , 0 - 100%
			1	7	7			43	000 - 255	RGBAL+UV Color Macros , see Color Macros section
		7		8	8		43	44	000 - 255	Background Red , 0 - 100%
		8		9	9		44	45	000 - 255	Background Green , 0 - 100%
		9		10	10		45	46	000 - 255	Background Blue , 0 - 100%
			2	11	11			47	000 - 255	RGB Background Color Macros , see Color Macros section
1			3	12	12			48	000 - 255	Color Temperature , 2300 - 9900K Linear
										White Color Temperature Presets
									000 - 022	Open
									023	2300K
									024	2400K
									025	2500K
									026	2600K
									027	2700K
									028	2800K
									029	2900K
									030	3000K
									031	3100K
									032	3200K
									033	3300K
									034	3400K
									035	3500K
									036	3600K
									037	3700K
									038	3800K
									039	3900K
									040	4000K
									041	4100K
									042	4200K
									043	4300K
									044	4400K
									045	4500K
									046	4600K

DMX TRAITS

CHANNEL									DMX VALUES	FUNCTION
5Ch	6Ch	9Ch	13Ch	22Ch	24Ch	42Ch	45Ch	60Ch		
2			4	13	13			49		<i>White Color Temperature Presets (continued)</i>
									047	4700K
									048	4800K
									049	4900K
									050	5000K
									051	5100K
									052	5200K
									053	5300K
									054	5400K
									055	5500K
									056	5600K
									057	5700K
									058	5800K
									059	5900K
									060	6000K
									061	6100K
									062	6200K
									063	6300K
									064	6400K
									065	6500K
									066	6600K
									067	6700K
									068	6800K
									069	6900K
									070	7000K
									071	7100K
									072	7200K
									073	7300K
									074	7400K
									075	7500K
076	7600K									
077	7700K									
078	7800K									
079	7900K									
080	8000K									
081	8100K									
082	8200K									
083	8300K									
084	8400K									
085	8500K									

DMX TRAITS

CHANNEL									DMX VALUES	FUNCTION
5Ch	6Ch	9Ch	13Ch	22Ch	24Ch	42Ch	45Ch	60Ch		
2			4	13	13			49		White Color Temperature Presets (continued)
									086	8600K
									087	8700K
									088	8800K
									089	8900K
									090	9000K
									091	9100K
									092	9200K
									093	9300K
									094	9400K
									095	9500K
									096	9600K
									097	9700K
									098	9800K
									099	9900K
	100 - 255	No Function								
3			5	14	14			50		Shutter, Strobe
									000 - 031	LEDs Off
									032 - 063	LEDs On
									064 - 095	Strobe Effect, slow to fast
									096 - 127	LEDs On
									128 - 159	Pulse Effect in Sequences
									160 - 191	LEDs On
									192 - 223	Random Strobe Effect, slow to fast
224 - 255	LEDs On									
4			6	15	15			51	000 - 255	Dimmer Intensity, 0 - 100%
5			7	16	16			52	000 - 255	Dimmer Fine Intensity

DMX TRAITS

CHANNEL									DMX VALUES	FUNCTION
5Ch	6Ch	9Ch	13Ch	22Ch	24Ch	42Ch	45Ch	60Ch		
			8	17	17			53		RGBAL+UV Programs
									000 - 010	Off
									011 - 026	Auto Program 1
									027 - 043	Auto Program 2
									044 - 060	Auto Program 3
									061 - 076	Auto Program 4
									077 - 093	Auto Program 5
									094 - 110	Auto Program 6
									111 - 126	Auto Program 7
									127 - 143	Auto Program 8
									144 - 160	Auto Program 9
									161 - 176	Auto Program 10
									177 - 193	Auto Program 11
									194 - 210	Auto Program 12
									211 - 226	Auto Program 13
									227 - 255	No Function
			9	18	18			54	000 - 255	RGBAL+UV Programs Speed, slow to fast
			10	19	19			55	000 - 255	RGBAL+UV Programs Fade, least to most
			11	20	20			56		RGB Background Programs
									000 - 010	Off
									011 - 026	Auto Program 1
									027 - 043	Auto Program 2
									044 - 060	Auto Program 3
									061 - 076	Auto Program 4
									077 - 093	Auto Program 5
									094 - 110	Auto Program 6
									111 - 126	Auto Program 7
									127 - 143	Auto Program 8
									144 - 160	Auto Program 9
									161 - 176	Auto Program 10
									177 - 193	Auto Program 11
									194 - 210	Auto Program 12
									211 - 226	Auto Program 13
									227 - 255	No Function
			12	21	21			57	000 - 255	RGB Background Programs Speed, slow to fast
			13	22	22			58	000 - 255	RGB Background Program Fade, least to most

DMX TRAITS

CHANNEL									DMX VALUES	FUNCTION	
5Ch	6Ch	9Ch	13Ch	22Ch	24Ch	42Ch	45Ch	60Ch			
					23			59		Dim Mode	
										000 - 020	Default to Unit Setting
										021 - 040	Standard
										041 - 060	Stage
										061 - 080	TV
										081 - 100	Architectural
										101 - 120	Theatre
										121 - 140	Stage 2
											Dim Speed
										141	0.1s
										142	0.2s
										143	0.3s
										144	0.4s
										145	0.5s
										146	0.6s
										147	0.7s
										148	0.8s
										149	0.9s
										150	1.0s
										151	1.5s
										152	2.0s
										153	3.0s
										154	4.0s
								155	5.0s		
								156	6.0s		
								157	7.0s		
								158	8.0s		
								159	9.0s		
								160	10.0s		
								161 - 255	Default to Unit Setting		
					24			60		Dim Curves	
										000 - 020	Square
										021 - 040	Linear
										041 - 060	Inv Squa
										061 - 080	S Curve
										081 - 255	No Function

COLOR MACROS CHART

RGBAL+UV COLOR MACROS

MACRO NO.	DMX VALUES	RED	GREEN	BLUE	AMBER	LIME	UV
Off	000	0	0	0	0	0	0
1	001 - 004	255	0	0	0	0	0
2	005 - 008	0	255	0	0	0	0
3	009 - 012	0	0	255	0	0	0
4	013 - 016	0	0	0	255	0	0
5	017 - 020	0	0	0	0	255	0
6	021 - 024	0	0	0	0	0	255
7	025 - 028	255	255	255	255	255	255
8	029 - 032	255	200	74	74	41	80
9	033 - 036	255	166	77	77	2	26
10	037 - 040	255	125	74	74	177	62
11	041 - 044	255	97	77	74	65	33
12	045 - 048	255	71	77	71	63	200
13	049 - 052	255	83	134	83	21	176
14	053 - 056	255	93	182	93	101	61
15	057 - 060	255	96	236	96	38	44
16	061 - 064	238	93	255	93	87	211
17	065 - 068	196	87	255	87	0	255
18	069 - 072	150	90	255	90	149	255
19	073 - 076	100	77	255	77	11	125
20	077 - 080	77	100	255	77	91	14
21	081 - 084	67	148	255	67	38	189
22	085 - 088	77	195	255	77	69	114
23	089 - 092	77	234	255	77	46	210
24	093 - 096	158	255	144	144	37	111
25	097 - 100	255	251	153	153	121	11
26	101 - 104	255	101	147	147	12	21
27	105 - 108	255	138	186	138	9	140
28	109 - 112	255	147	251	27	23	255
29	113 - 116	151	138	255	138	50	196
30	117 - 120	99	0	255	100	0	255
31	121 - 124	138	169	255	138	19	212
32	125 - 128	255	243	77	77	40	86
33	129 - 132	255	206	143	0	0	0
34	133 - 136	254	177	153	0	0	0
35	137 - 140	254	192	138	0	0	0
36	141 - 144	254	165	98	0	0	0

COLOR MACROS CHART

RGBAL+UV COLOR MACROS

MACRO NO.	DMX VALUES	RED	GREEN	BLUE	AMBER	LIME	UV
37	145 - 148	254	121	0	0	0	0
38	149 - 152	176	17	0	0	0	0
39	153 - 156	96	0	11	0	0	0
40	157 - 160	234	139	171	0	0	0
41	161 - 164	224	5	97	0	0	0
42	165 - 168	175	77	173	0	0	0
43	169 - 172	119	130	199	0	0	0
44	173 - 176	147	164	212	0	0	0
45	177 - 180	88	2	163	0	0	0
46	181 - 184	0	38	86	0	0	0
47	185 - 188	0	142	208	0	0	0
48	189 - 192	52	148	209	0	0	0
49	193 - 196	1	134	201	0	0	0
50	197 - 200	0	145	212	0	0	0
51	201 - 204	0	121	192	0	0	0
52	205 - 208	0	129	184	0	0	0
53	209 - 212	0	83	115	0	0	0
54	213 - 216	0	97	166	0	0	0
55	217 - 220	1	100	167	0	0	0
56	221 - 224	0	40	86	0	0	0
57	225 - 228	209	219	182	0	0	0
58	229 - 232	42	165	85	0	0	0
59	233 - 236	0	46	35	0	0	0
60	237 - 240	8	107	222	0	0	0
61	241 - 244	80	255	234	0	0	0
62	245 - 248	80	255	164	0	0	0
63	249 - 252	77	255	112	0	0	0
64	253 - 255	117	255	83	0	0	0

COLOR MACROS CHART

BACKGROUND COLOR MACROS

MACRO NO.	DMX VALUES	RED	GREEN	BLUE
Off	000	0	0	0
1	001 - 004	80	255	234
2	005 - 008	80	255	164
3	009 - 012	77	255	112
4	013 - 016	117	255	83
5	017 - 020	160	255	77
6	021 - 024	223	255	83
7	025 - 028	255	243	77
8	029 - 032	255	200	74
9	033 - 036	255	166	77
10	037 - 040	255	125	74
11	041 - 044	255	97	77
12	045 - 048	255	71	77
13	049 - 052	255	83	134
14	053 - 056	255	93	182
15	057 - 060	255	96	236
16	061 - 064	238	93	255
17	065 - 068	196	87	255
18	069 - 072	150	90	255
19	073 - 076	100	77	255
20	077 - 080	77	100	255
21	081 - 084	67	148	255
22	085 - 088	77	195	255
23	089 - 092	77	234	255
24	093 - 096	158	255	144
25	097 - 100	255	251	153
26	101 - 104	255	175	147
27	105 - 108	255	138	186
28	109 - 112	255	147	251
29	113 - 116	151	138	255
30	117 - 120	99	0	255
31	121 - 124	138	169	255
32	125 - 128	61	4	167
33	129 - 132	255	206	143
34	133 - 136	254	177	153
35	137 - 140	254	192	138
36	141 - 144	254	165	98

COLOR MACROS CHART

BACKGROUND COLOR MACROS

MACRO NO.	DMX VALUES	RED	GREEN	BLUE
37	145 - 148	254	121	0
38	149 - 152	176	17	0
39	153 - 156	96	0	11
40	157 - 160	234	139	171
41	161 - 164	224	5	97
42	165 - 168	175	77	173
43	169 - 172	119	130	199
44	173 - 176	147	164	212
45	177 - 180	88	2	163
46	181 - 184	0	38	86
47	185 - 188	0	142	208
48	189 - 192	52	148	209
49	193 - 196	1	134	201
50	197 - 200	0	145	212
51	201 - 204	0	121	192
52	205 - 208	0	129	184
53	209 - 212	0	83	115
54	213 - 216	0	97	166
55	217 - 220	1	100	167
56	221 - 224	0	40	86
57	225 - 228	209	219	182
58	229 - 232	42	165	85
59	233 - 236	0	46	35
60	237 - 240	8	107	222
61	241 - 244	255	0	0
62	245 - 248	0	255	0
63	249 - 252	0	0	255
64	253 - 255	255	255	255

PIXEL FLIP

Pixel Flip 1 (Default)

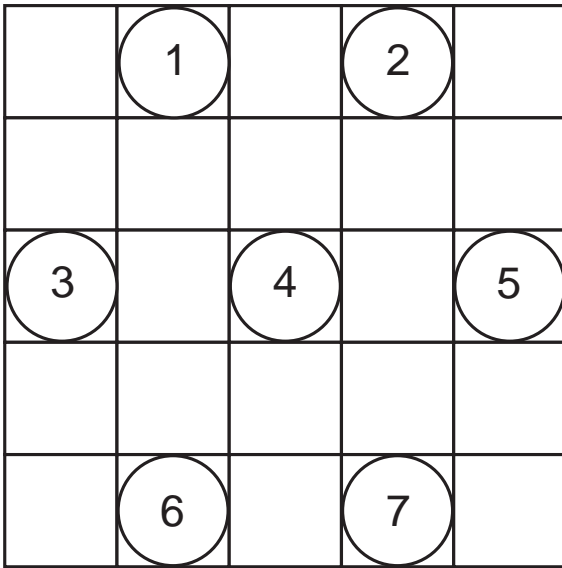

Pixel Flip 2

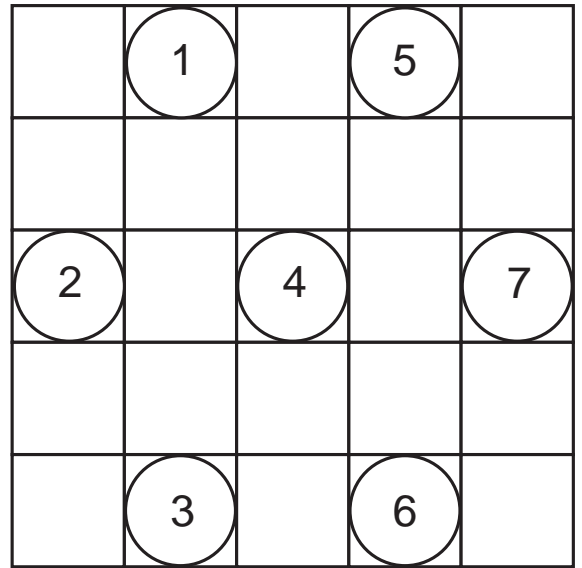

Pixel Flip 3

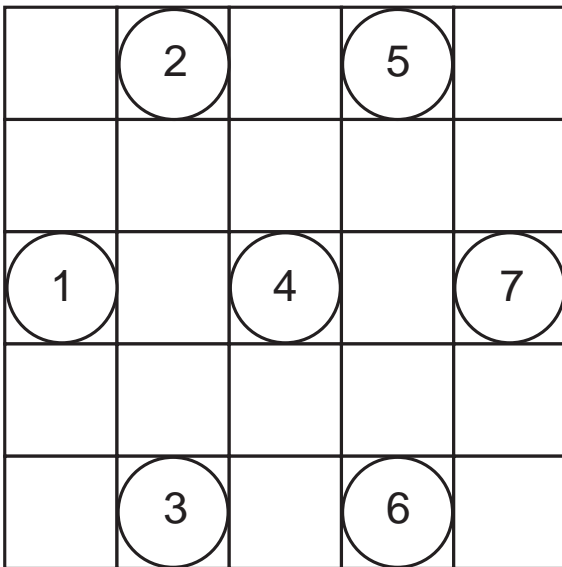

Pixel Flip 4

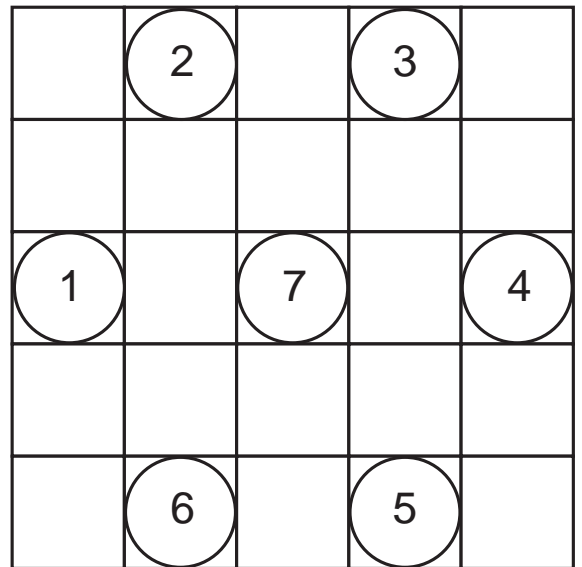

DIM MODES

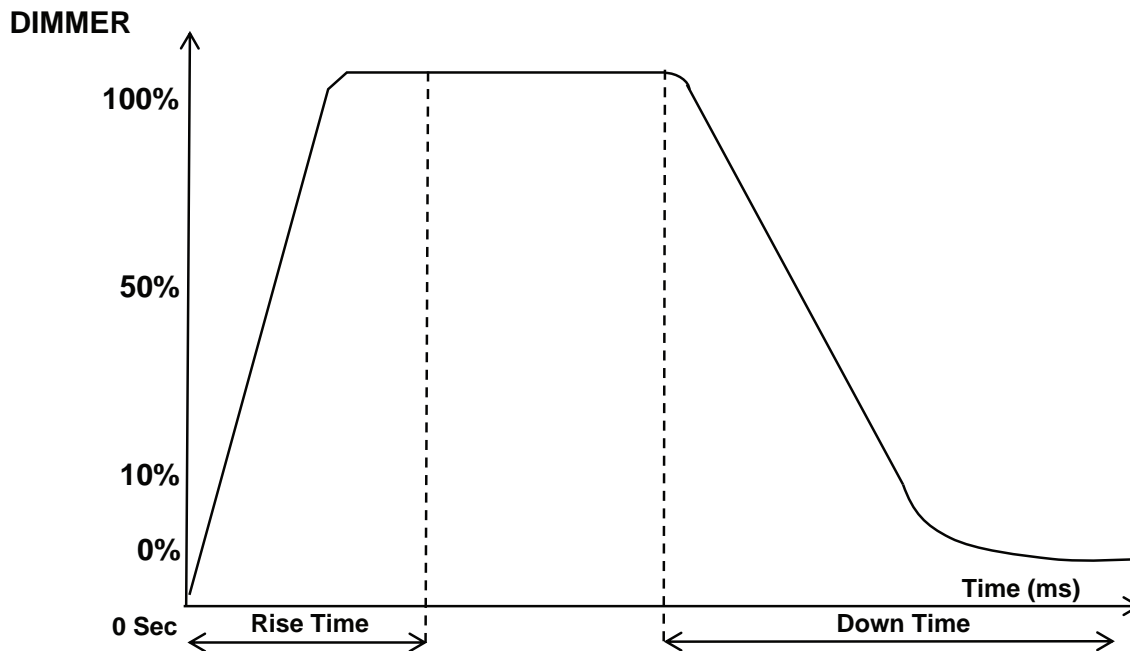

Dimming Curve Ramp Effect	0 sec Fade Time		1 sec Fade Time	
	Rise Time (ms)	Down Time (ms)	Rise Time (ms)	Down Time (ms)
Standard (default)	0	0	0	0
Stage	780	1100	1540	1660
TV	1180	1520	1860	1940
Architectural	1380	1730	2040	2120
Theatre	1580	1940	2230	2280
Stage 2	0	1100	0	1660

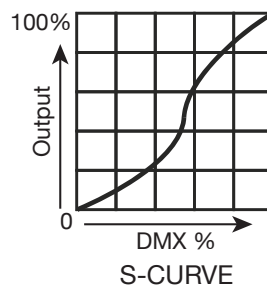
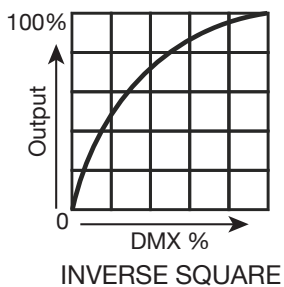
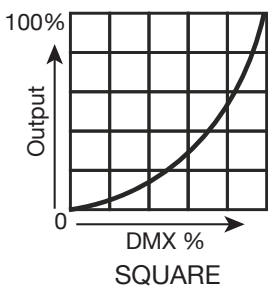
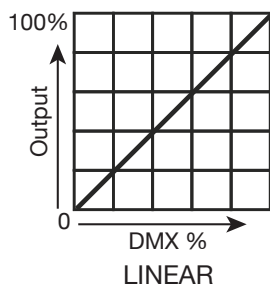

PRIMARY-SECONDARY SETUP

This function allows you to link units together to run in a Primary-Secondary set-up, in which one unit will act as the controlling unit and the others will react to the controlling unit's built-in programs. Any unit can be configured to act as a Primary or as a Secondary, but only one unit in a given system can be programmed to act as the Primary.

Primary-Secondary Connections and Settings:

1. Daisy chain your units via the XLR connectors on the bottom of each unit. Use standard XLR data cables to link your units together. Remember that the male XLR connector is the input and the female XLR connector is the output. The first unit in the chain (primary) will use the female XLR connector only. The last unit in the chain will use the male XLR connector only.
2. On the unit that you want to designate as the primary, use the display screen and control panel to navigate to Personality > Prim/Sec Mode, then select "Primary" and press the SETUP button to confirm. Configure the operation of the device as desired.
3. On the units that you want to designate as secondaries, use the display screen and control panel to navigate to Personality > Prim/Sec Mode, then select "Secondary" and press the SETUP button to confirm. The secondary units will now follow the operation of the primary unit.

NOTES:

- Only one unit should be configured as the primary, while all the other units should be configured as secondaries.
- All units should be set to the same DMX channel mode.
- If fixtures fail to sync, verify that all settings mentioned above are the same, then power all devices off, then switch them on again to re-establish the link.

MULTI UNIT POWER LINKING

This feature allows you to connect the fixtures to one another using the power cable input and output sockets.

The maximum number of units that can be linked in this manner is as follows:

- 10 units when running on 120V power.
- 18 units when running on 230V power.

DO NOT EXCEED THIS MAXIMUM NUMBER WHEN POWER LINKING UNITS!

All linked units must be of the same make and model type. Do not mix and match units!

MAINTENANCE GUIDELINES



DISCONNECT POWER BEFORE PERFORMING ANY MAINTENANCE!

CLEANING

Frequent cleaning is recommended to ensure proper function, optimized light output, and an extended life. The frequency of cleaning depends on the environment in which the fixture operates: damp, smoky, or particularly dirty environments can cause greater accumulation of dirt on the fixture's optics. Clean the external lens surface regularly with a soft cloth to avoid dirt/debris accumulation.

NEVER use alcohol, solvents, or ammonia-based cleaners.

MAINTENANCE

Regular inspections are recommended to ensure proper function and extended life. There are no user serviceable parts inside this fixture. Please refer all other service issues to an authorized ADJ service technician. Should you need any spare parts, please order genuine parts from your local ADJ dealer.

Please refer to the following points during routine inspections:

- A. A detailed electrical check by an approved electrical engineer every three months, to make sure the circuit contacts are in good condition and prevent overheating.
- B. Be sure all screws and fasteners are securely tightened at all times. Loose screws may fall out during normal operation, resulting in damage or injury as larger parts could fall.
- C. Check for any deformations on the housing, color lenses, rigging hardware, and rigging points (ceiling, suspension, trussing). Deformations in the housing could allow for dust to enter into the fixture. Damaged rigging points or unsecured rigging could cause the fixture to fall and seriously injure a person(s).
- D. Electric power supply cables must not show any damage, material fatigue, or sediments.

NEVER remove the ground prong from the power cable.

TORQUE SETTINGS FOR SCREWS

IN ORDER TO MAINTAIN THE IP65 RATING ON THE LIGHTING FIXTURES, ALL SCREWS MUST BE TIGHTENED TO THE FOLLOWING TORQUE SPECIFICATION USING A TORQUE DRIVER.

Refer to the table and diagram below for torque specifications.

TORQUE DRIVERS (Recommended): UTICA TS-30 (shown)

ALTERNATE DRIVERS:

- Proto J6107A
- Wiha 28887



CAUTION! DO NOT OVER TORQUE SCREWS, AS THIS CAN CAUSE LEAKAGE ISSUES!

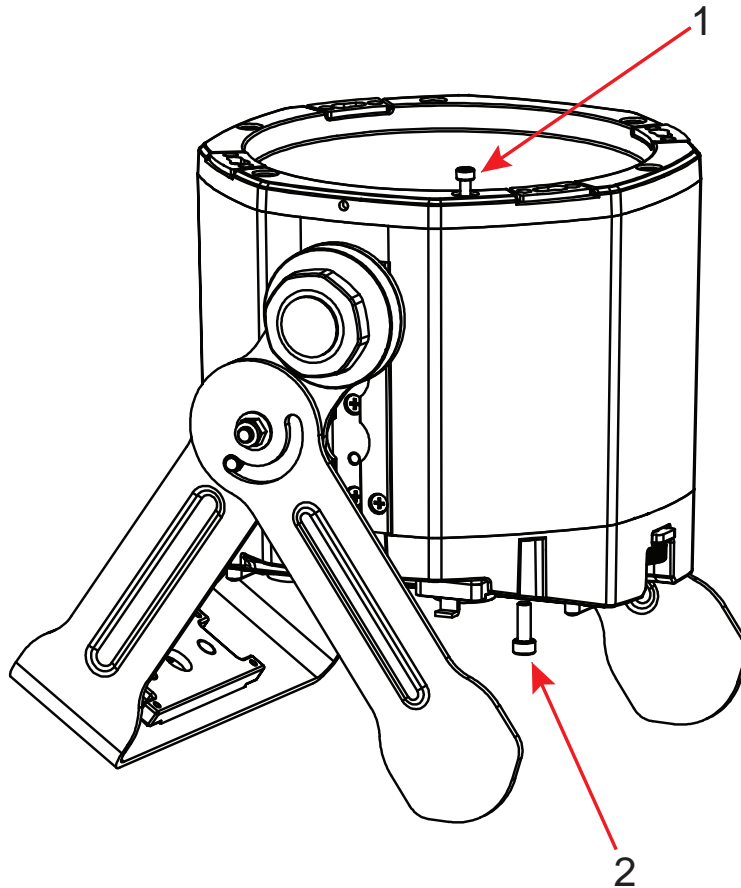

NO.	LOCATION	QUANTITY	TORQUE
1	Upper Cover	6	10.4 lb-in (12 kg-cm)
2	Back Cover	4	17.4 lb-in (20 kg-cm)

IP TEST PARAMETERS

Following any repair or maintenance procedure that requires disassembly of the fixture, use ADJ's Hydro IP Tester to confirm the IP integrity of the fixture. The air valve is located on the back panel next to the display screen, as shown in the diagram below. Please contact ADJ Service for information regarding the ADJ Hydro IP Tester, or visit the product information page online at: <https://www.adj.com/hydro-ip-tester>

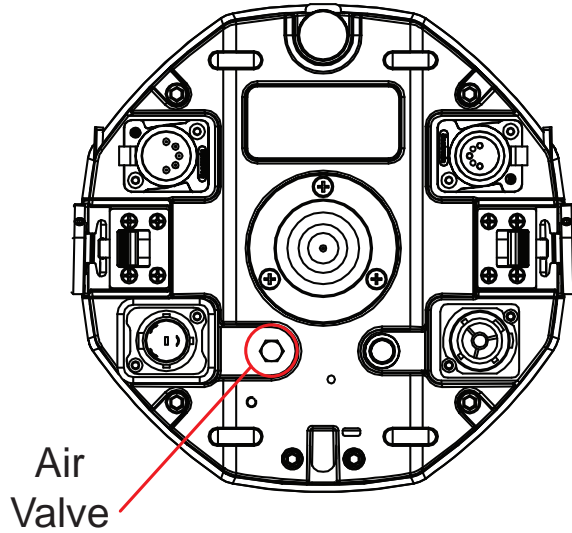

CAUTION! THE USE OF PROTECTIVE GLOVES AND SAFETY GOGGLES IS STRONGLY RECOMMENDED WHILE PERFORMING THE IP PRESSURE TEST! AVOID PLACING YOUR FACE, EYES, HANDS, ETC IN CLOSE PROXIMITY TO THE FIXTURE'S LENS WHILE PERFORMING THE TEST!

DE-HUMIDIFICATION: IP65 fixtures operating in high-humidity environments may experience residual fogging or condensation. Such fogging will not damage the fixture, and can be removed using the following procedure: position the unit with the air valve pointing upwards, then open the air valve and run the unit for 1-2 hours after reaching operating temperature. Then, while the fixture is still hot, re-install the air valve and allow the unit to cool down. Please note that this procedure should be performed in a dry, air-conditioned environment. Avoid additional fogging by drying the fixture completely before placing into a road case.



IP PRESSURE TESTING PARAMETERS		
Low Pressure Limit	High Pressure Limit	Steady/Hold Time
1.65 psi (11.4 KPa)	1.70 psi (11.7 KPa)	3 sec

DIMENSIONAL DRAWINGS

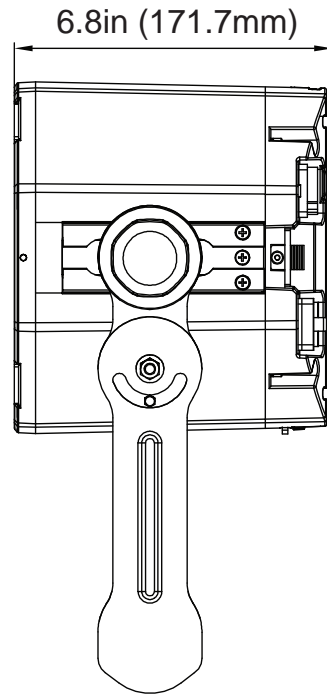
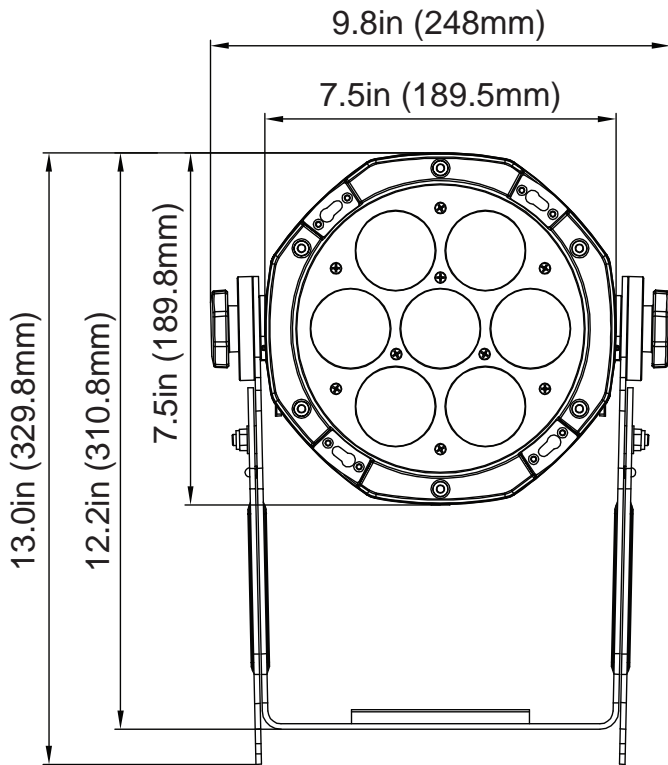
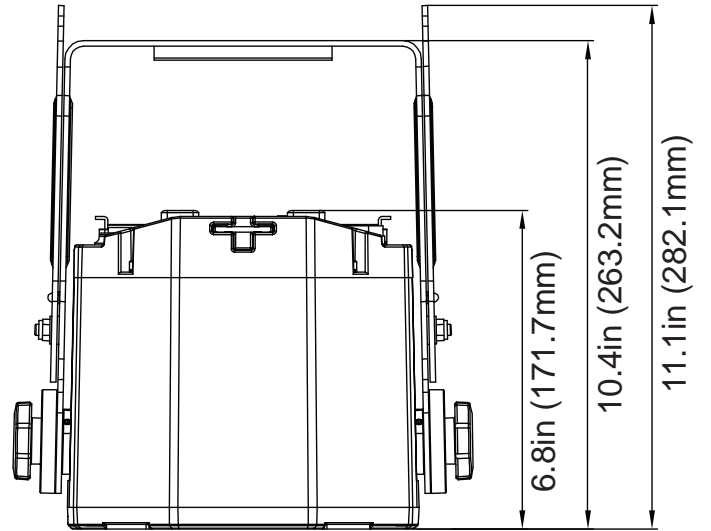
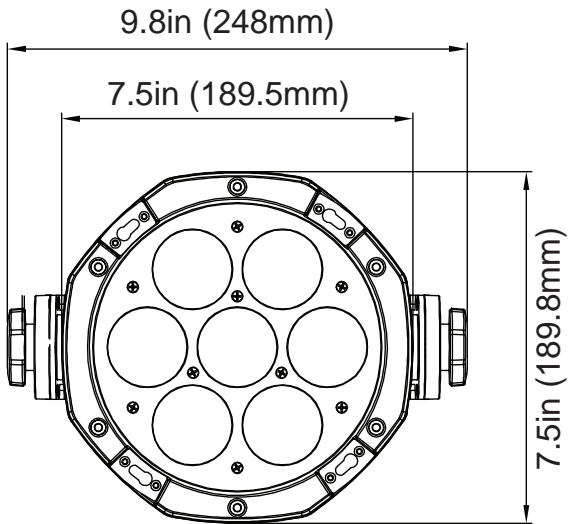

SPECIFICATIONS

Source:

- (7) 20W Hex Color RGBAL+UV Foreground LED's
- (29) 0.2W RGB Background LED's
- 50,000 Hour Average Life*
- *May vary depending on several factors including but not limited to: Environmental Conditions, Power/Voltage, Usage Patterns (On-Off Cycling), Control, and Dimming.

Optical:

- 2,300K ~ 9,900K White Color Temperature Range
- 17° Beam Angle
- 45mm Lens Diameter x7

Physical:

- IP65 Housing
- OLED Digital display
- L Track system for locking accessories / rigging
- Gel Frame Holder
- Adjustable, hanging / kick stand bracket

Control:

- DMX512
- Aria X2 Wireless DMX
- Bluetooth
- RDM and RDM Net Compatible
- IR (Includes UCIR24 wireless remote)
- (9) DMX Channel Modes (5, 6, 9, 13, 22, 24, 42, 45 & 60 Channel modes)
- On-board Manual Control Mode
- Primary / Secondary Mode

Connections:

- 5pin XLR Outdoor DMX In/Out Sockets (Must be used with STRxxx, 5pin DMX cables to create IP65 seal)
- Outdoor Locking Power Sockets
- Battery Charging Socket

Dimensions & Weight:

- Length: 11.11" (282.1mm)
- Width: 9.8" (248mm)
- Height: 7.46" (189.5mm)
- Weight: 18.1 lbs. (8.2 kg)

Power:

- AC100-240V/50Hz-60Hz Input
- 90W Power Consumption
- Link 10 pieces @ 120VAC or 18 pieces @ 230VAC

Battery:

- Rechargeable Lithium ion
- Battery Capacity: 12,000mAh
- Battery Voltage: 22.2V
- Charge Time, AC Power: 5 Hours (To Full)
- Charge Time, Flight Case: 7 Hours (To Full)
- Battery operation can be selected by the user for durations ranging from 5 to 20 hours. 5 Hour duration will operate at Full Output when battery is fully charged
- Battery Cycles: 500

Thermal:

- Ambient Operational Temperature: -4°F to 113°F (-20°C to 45°C)
- Storage Temperature: -22°F to 113°F (-30°C to 45°C)

Certifications & IP Rating:

- CE
- cETLus (Pending)
- FCC
- IP65

ORDERING INFORMATION

US SKU	EU SKU	DESCRIPTION
ELE700	1226100504	ElectraPix Par 7
LTR008	Pending	LTrack A2 - Ltrack Adapter Only
LTR112	Pending	LTrack CA2 - LTrack Adapter with Narrow Clamp
ELP404	Pending	ELP12IPBDA - Barn Door and Gel Frame Assembly
ELP755	Pending	ELPIX7L55 - 55° Diffusion Filter
ELP740	Pending	ELPIX7L40 - 40° Diffusion Filter
ELP730	Pending	ELPIX7L30 - 30° Diffusion Filter
ELP720	Pending	ELPIX7L20 - 20° Diffusion Filter
ELP781	Pending	ELPIX7L30X60 - 30x60° Linear Filter
ELP801	Pending	ELPIX7L15X60 - 15x60° Linear Filter
ELP794	Pending	ELPIX7L10X60 - 10x60° Linear Filter
ELP768	Pending	ELPIX7L10X40 - 10x40° Linear Filter
MIR639	Pending	EPIX P7 IPCB - Replacement Charging Base and Power Supply

FCC STATEMENT

This device complies with Part 15 of the FCC Rules. Operation is subject to the following two conditions: (1) this device may not cause harmful interference, and (2) this device must accept any interference received, including interference that may cause undesired operation.

FCC RADIO FREQUENCY INTERFERENCE WARNINGS & INSTRUCTIONS

This product has been tested and found to comply with the limits as per Part 15 of the FCC Rules. These limits are designed to provide reasonable protection against harmful interference in a residential installation. This device uses and can radiate radio frequency energy and, if not installed and used in accordance with the included instructions, may cause harmful interference to radio communications. However, there is no guarantee that interference will not occur in a particular installation. If this device does cause harmful interference to radio or television reception, which can be determined by turning the device off and on, the user is encouraged to try to correct the interference by one or more of the following methods:

- Reorient or relocate the device.
- Increase the separation between the device and the receiver.
- Connect the device to an electrical outlet on a circuit different from which the radio receiver is connected.
- Consult the dealer or an experienced radio/TV technician for help.

Europe Energy Saving Notice

Energy Saving Matters (EuP 2009/125/EC)

Saving electric energy is a key to help protecting the environment. Please turn off all electrical products when they are not in use. To avoid power consumption in idle mode, disconnect all electrical equipment from power when not in use. Thank you



